

SMOKE EXTRACTION



# PYROSTAR®

## RANGE

Smoke extraction unit F400-120  
Belt and pulley transmission  
Impulse or reaction wheel  
Air flow 600 to 50 000 m<sup>3</sup>/h  
NF EN 12101-3 compliant

# 03





Approved CSTB F400-120 / NF EN 12101-3  
Marking EC ventilators extractors of smokes and heat



Certificate number  
0679 - CPR - 0949



## APPLICATION

- Smoke extraction units meeting legislative requirements for the extraction of smoke and hot gases in the event of fire in high rise buildings and public assembly buildings.
- Range also designed for the extraction of contaminated air from industrial premises, professional kitchens and car parks, etc.
- ✦ The **PYROSTAR®** program is F400-120 approved by the CSTB and covered by the CE certificate for smoke and heat extractor fans which comply with standard NF EN 12101-3.

## RANGE

- Available in 5 sizes and 20 models, the **PYROSTAR®** range covers

air flows from 600 to 50 000 m<sup>3</sup>/hr either in impulse wheel

version, **PYROSTAR® A** for pressures up to 1 500 Pa or reaction wheel version, **PYROSTAR® R** for pressures up to 2 600 Pa.

- ✦ The **PYROSTAR® R** version fitted with a reaction wheel is especially suitable and recommended for applications in professional kitchens or for the extraction of foul contaminated air (car parks, industry, etc.).

## CONSTITUTION

- Housing in 15/10 galvanized steel sheet free standing on 20 to 30/10 galvanized steel frame from reinforced by a central strut from model **PYROSTAR® 25** on.
- ✦ Access panel fitted with a hinged door with handle for the technical room compartment and wide removable panel for maintaining the fan.
- Ground fixings fit directly into the slots provided in the frame.
- ✦ Intake and discharge by circular connections up to **PYROSTAR® 12**, square on the other models.
- The motor support consists of a galvanized steel plate reinforced by raised edges fully extractable and sliding on rails for maintenance and adjustment. The design of the motor compartment enables the overall dimensions of the unit to be limited with the option of blocking off the side opposite the access face. The transmission tension is adjusted from the outside, outlet face side, by a system using a frame sliding on rails.
- Impulse wheel and double opening (**PYROSTAR® A** version) in galvanized steel, balanced statically and dynamically, fitted with an aluminium hub and coupled to the motor by belt(s) and pulley(s).
- ✦ Reaction wheel with double opening, high efficiency and easy to clean (**PYROSTAR® R**), in steel protected by epoxy paint, balanced statically and dynamically, fitted with an aluminium hub and coupled to the motor by belt(s) and pulley(s).
- B3 motor, protection IP 55 class F overheating B.

- 1 speed three-phase 230/400V or 400/690V (motor of about 5.5 kW), 50 or 60 Hz, (2 and 4 poles).
- 2 speed three-phase 400V, 50 Hz, Dahlander winding (2/4 and 4/8 P), independent windings (4/6 P).
- Protective housing for the transmission on the fan compartment side, easily removable for belt replacement.
- ✦ Variable drive pulley up to 5.5 kW.

## INSTALLATION

- ✦ The **PYROSTAR** range can be installed indoors or outdoors.
- Access is on the right, viewed in the air direction, as standard, on the left on request or can be easily changed on site if required.
- Outlet horizontal in line or vertical at 90°.
- ✦ Can be installed vertically against a wall.

## VARIANTS F400-120 APPROVED BY THE CSTB

- Acoustic insulation in very high density 25 mm 120 kg/m<sup>3</sup> mineral wool providing powerful acoustic attenuation (IPH option).
- Double skin insulation (IDP), standard external face in 15/10 galvanized sheet, internal face in 10/10 galvanized sheet and insulation in high density mineral wool, 25 mm - 60 kg/m<sup>3</sup>. Recommended for installations requiring regular maintenance of the unit while providing attenuation of the sound levels radiated (professional kitchens, etc.).
- ✦ The IPH and IDP variants classify the **PYROSTAR®** range up to model 12 in the category of F400-120 **THERMALLY INSULATED** smoke extraction fans Approved and certified by the CSTB.
- Condensate tray at bottom of unit (ECP option) for removal of condensates.  
Compatible with the standard or IDP versions.

## OPTIONS

- ✦ Numerous installation, operating, control and regulation are available and approved F400-120 by the CSTB.

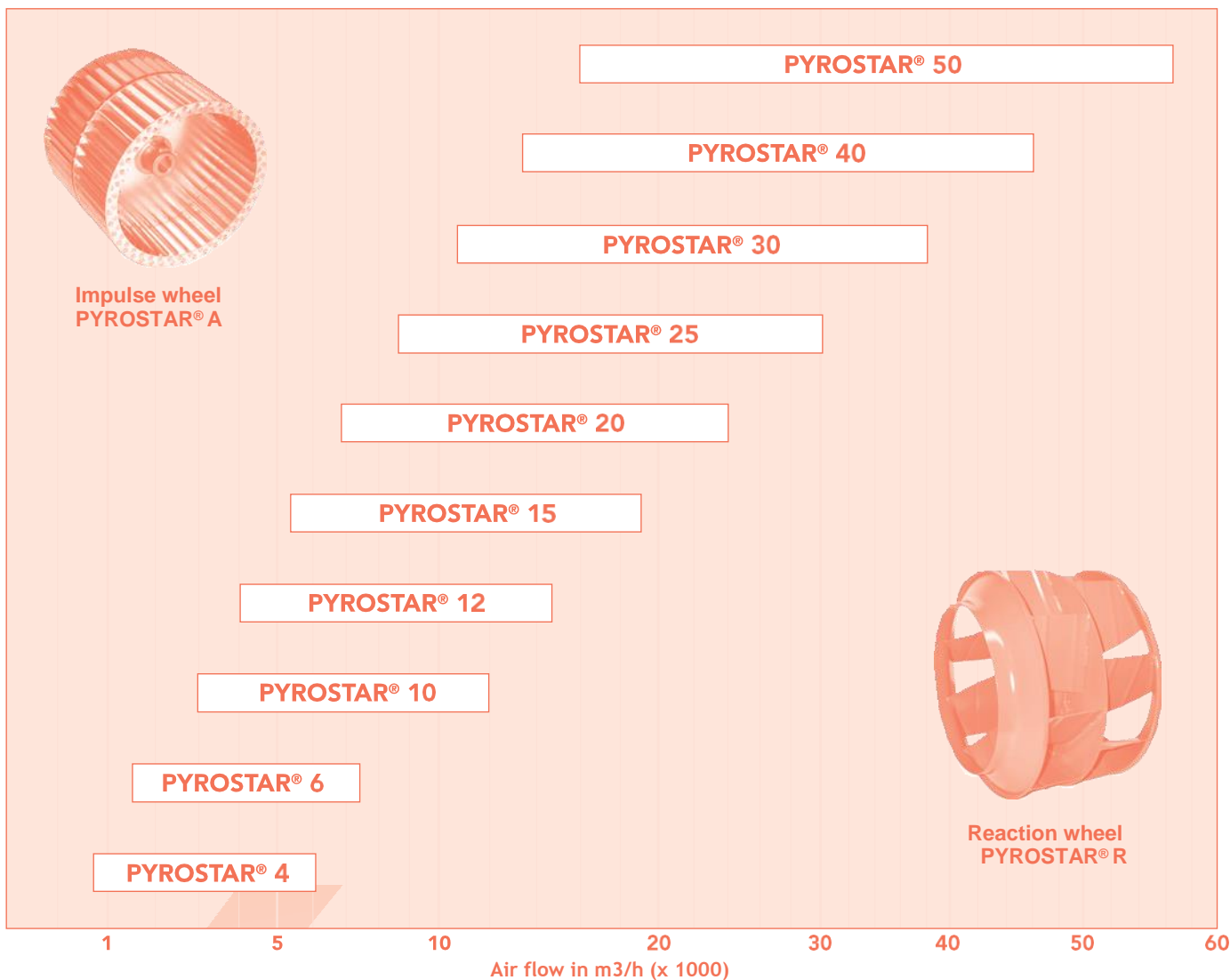

INSTALLATION CONFIGURATIONS **PYROSTAR®**



Horizontal in-line intake and discharge - (H)



Horizontal intake and vertical discharge - (V)



Standard access to the right or left viewed in the air direction.



Access to the left viewed in the air direction on request or modifiable on site

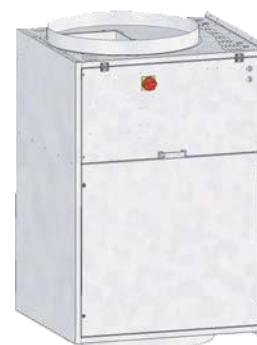

Vertical fitting for models **PYROSTAR®** 4 to 12 only (fitted with motor ≤ 5.5 kW)

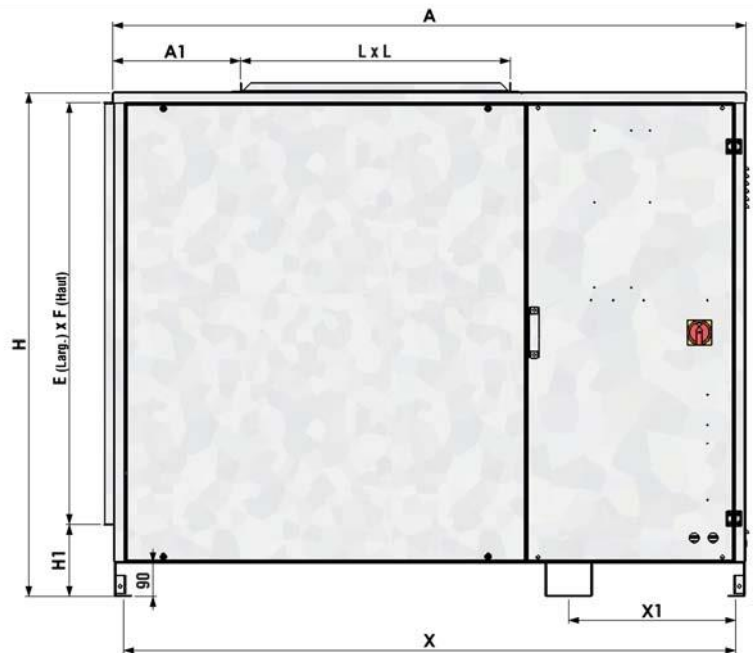
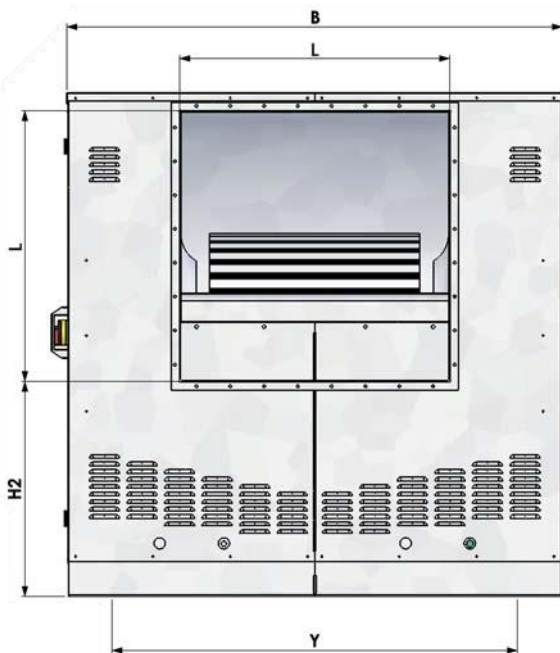
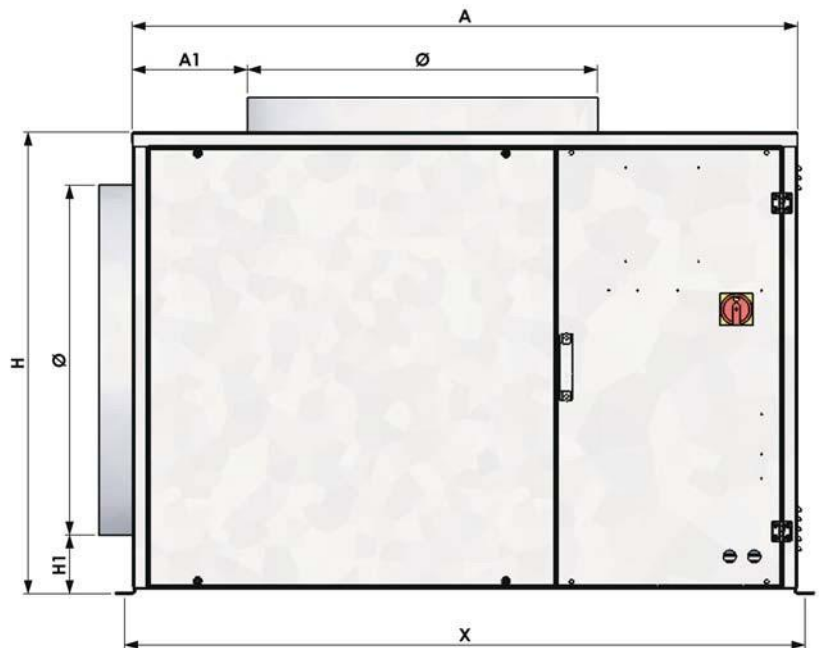
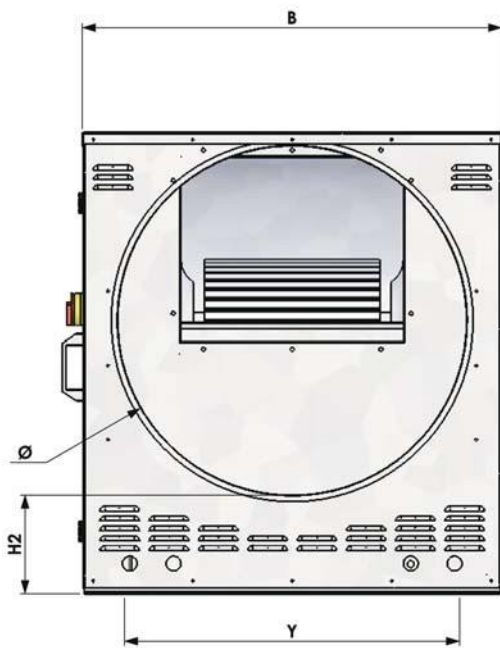

PYROSTAR® model	Dimensions				Air handling fittings						Ground fixing		
	A mm	B mm	H mm	Ø mm	E mm	F mm	L mm	A1 mm	H1 mm	H2 mm	X mm	X1 mm	Y mm
PYROSTAR® 4 A-R	1055	650	745	450	-	-	-	210	155	240	1090	-	520
PYROSTAR® 6 A-R	1055	650	745	500	-	-	-	170	130	215	1090	-	520
PYROSTAR® 10 A-R	1350	850	940	630	-	-	-	300	160	270	1380	-	680
PYROSTAR® 12 A-R	1350	850	940	710	-	-	-	235	120	200	1380	-	680
PYROSTAR® 15 A-R	1450	1070	1170	-	868	947	513	355	190	575	1390	-	840
PYROSTAR® 20 A-R	1450	1070	1170	-	868	947	575	290	190	545	1390	-	840
PYROSTAR® 25 A-R	1685	1320	1345	-	1122	1122	644	420	190	570	1630	445	1080
PYROSTAR® 30 A-R	1685	1320	1345	-	1122	1122	721	340	190	575	1630	445	1080
PYROSTAR® 40 A-R	1955	1660	1485	-	1458	1262	807	525	190	565	1900	445	1380
PYROSTAR® 50 A-R	1955	1660	1485	-	1458	1262	904	430	190	530	1900	445	1380

# EXCLUSIVE CONFIGURATIONS PYROSTAR®



## PADLOCKABLE LOCAL SWITCH

Installed as standard over the whole range.



## FACTORY-WIRED ASSEMBLY, RELAY UNIT ref. CDF® AND SPEED CONTROLLER ref. VFT

Separate or combined, these factory-fitted configurations are F400-120 / NF EN12101-3 approved by the CSTB. Only the VFT speed controller (three-phase input/output) is compatible with this certification in comfort/smoke extraction applications.

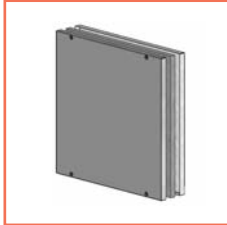

## THERMALLY-INSULATED FAN

The IPH and IDP variants also enable the PYROSTAR® range up to model 12 to be classified in the category of F400-120 THERMALLY INSULATED smoke extraction fans. Approved and certified by the CSTB.

# ACOUSTIC CHARACTERISTICS PYROSTAR®

- The NSC6 dBA values (○) shown in the curves relate to the sound level at 6m in free field from a PYROSTAR® standard unit connected at the intake and discharge by a duct with the same acoustic insulation as that of the unit. For PYROSTAR® units with IPH acoustic insulation, deduct 9 dB(A) from the values shown. For units with double skin insulation, IDP version, use an attenuation of 12 dB(A).
- To obtain the acoustic power spectrum at the intake of the unit connected in dB(A) gain, take the NSC6 power sound shown on the curves (○) and the apply the correction coefficients in the table below according to the PYROSTAR® model selected.

Unit model	Type	63 Hz	125 Hz	250 Hz	500 Hz	1 kHz	2 kHz	4 kHz	8 kHz
PYROSTAR® 4	A	8	17	21	25	27	26	22	16
	R	1	12	17	25	28	25	17	9
PYROSTAR® 6	A	7	16	21	24	27	26	22	15
	R	1	11	18	23	27	26	25	12
PYROSTAR® 10	A	8	17	21	25	27	26	22	16
	R	8	7	18	29	26	25	20	13
PYROSTAR® 12	A	8	17	22	25	27	27	22	16
	R	2	6	22	27	27	25	23	16
PYROSTAR® 15	A	7	16	21	24	27	26	22	15
	R	4	8	23	26	26	26	21	14
PYROSTAR® 20	A	8	17	21	25	27	26	22	16
	R	1	11	25	26	26	25	21	13
PYROSTAR® 25	A	8	17	22	25	27	26	22	16
	R	0	11	27	28	24	23	18	11
PYROSTAR® 30	A	8	17	21	25	27	26	22	16
	R	4	12	25	25	26	25	20	12
PYROSTAR® 40	A	7	16	21	24	27	26	22	15
	R	0	9	22	27	27	26	19	8
PYROSTAR® 50	A	7	16	21	24	27	26	22	15
	R	5	14	25	26	27	23	18	8

- If the PYROSTAR® unit has type IPH or IDP construction variants, add the attenuations shown below.

Construction Variant	Type	63 Hz	125 Hz	250 Hz	5 Hz	1 kHz	2 kHz	4 kHz	8 kHz
Sound insulation	IPH	0	-1	-2	-3	-3	-4	-5	-6
Double skin insulation	IDP	0	0	-1	-1	-2	-3	-2	-2

- To define the sound pressure level dB(A) in free field at a certain distance, device on the floor, outlet free, unit connected upstream, add the values from the table below to the NSC6 sound level value (○) shown in the curves.

Distance (m)	1,5	3	4	5	7	10
PYROSTAR® A	24	18	15	13	10	7
PYROSTAR® R	21	15	12	10	7	4



PYROSTAR® 4A

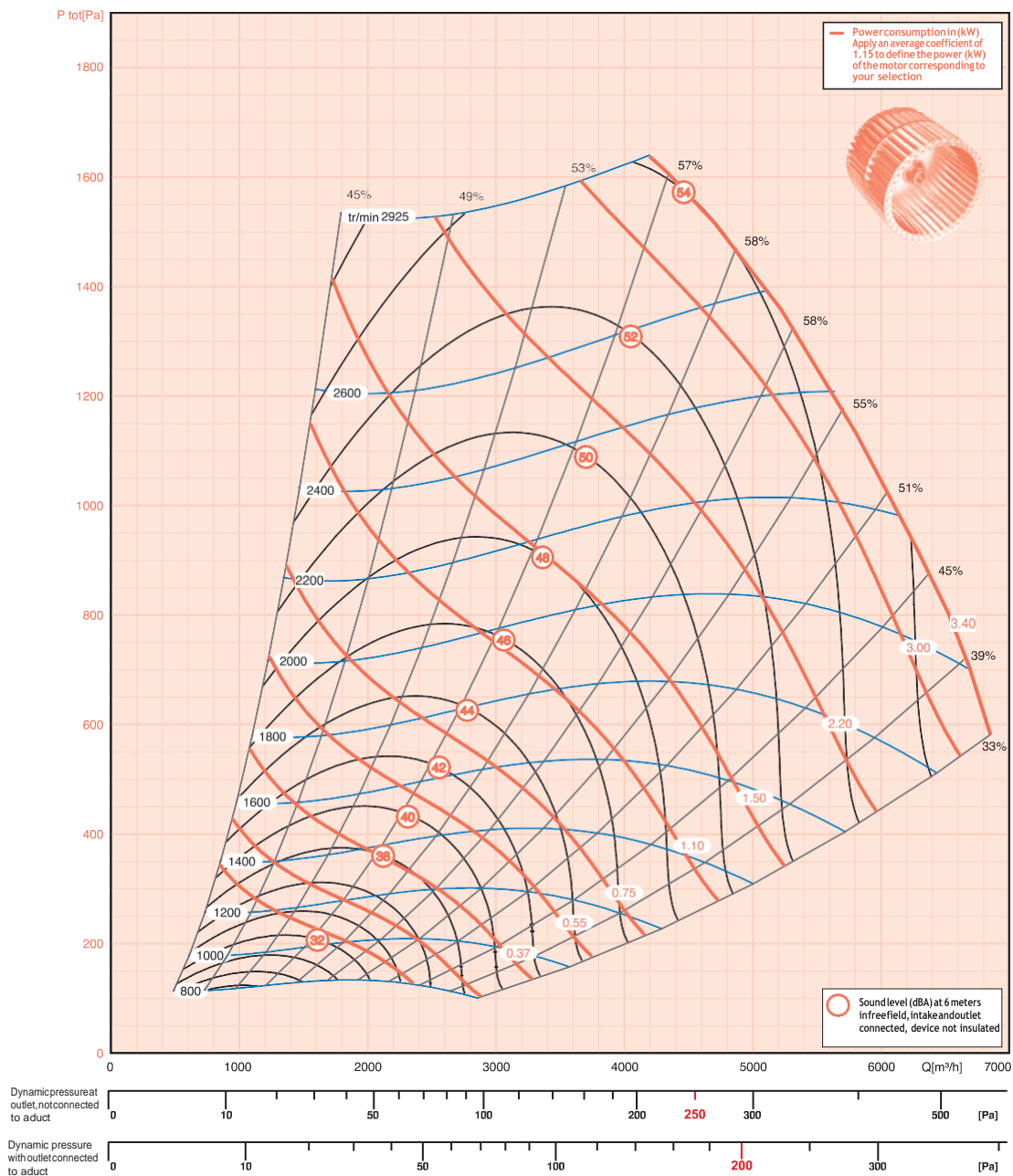

Motor 1 speed 400 V three-phase 50 Hz 2 and 4 poles				
PYROSTAR® Model	P. motor	Int.	Cos	Weight (kg)
4A B4 (H/V)	0,37	1,1	0,76	105
4A C4 (H/V)	0,55	1,6	0,76	105
4A D4 (H/V)	0,75	1,9	0,73	105
4A E4 (H/V)	1,10	2,6	0,79	110
4A F2 (H/V)	1,50	3,3	0,83	110
4A F4 (H/V)	1,50	3,4	0,73	110
4A G2 (H/V)	2,20	4,5	0,86	115
4A G4 (H/V)	2,20	4,9	0,79	115
4A H2 (H/V)	3,00	5,9	0,87	120
4A H4 (H/V)	3,00	6,5	0,79	125
4A I2 (H/V)	4,00	7,7	0,88	125
4A I4 (H/V)	4,00	8,6	0,79	125

Motor 2 speed 400 V three-phase -50Hz 2/4 and 4/8 poles Dahlander				
PYROSTAR® Model	Motor pwr. (kW)	Rated current (A)	Cos	Weight (kg)
4A B48 (H/V)	0,37/0,09	1,32/0,5	0,71/0,62	105
4A C48 (H/V)	0,55/0,13	1,8/0,91	0,71/0,62	120
4AD48 (H/V)	0,75/0,17	2,1/1,02	0,78/0,63	120
4A E48 (H/V)	1,10/0,26	2,9/1,51	0,79/0,61	120
4A F24 (H/V)	1,50/0,33	3,5/1,27	0,89/0,71	120
4A F48 (H/V)	1,50/0,35	4/1,81	0,81/0,60	120
4A G24 (H/V)	2,20/0,45	4,6/1,72	0,88/0,64	120
4A G48 (H/V)	2,20/0,50	5,2/2,6	0,81/0,58	120
4AH24 (H/V)	3,00/0,60	6,2/1,91	0,90/0,74	135
4AH48 (H/V)	3,00/0,65	6,8/3	0,81/0,57	135
4A I24 (H/V)	4,00/1,00	8,4/2,58	0,92/0,78	135
4A I48 (H/V)	4,00/1,00	8,6/3,5	0,83/0,60	135

Motor 2 speed 400 V three-phase -50Hz 4/6 poles separate windings				
PYROSTAR® Model	Motor pwr. (kW)	Rated current (A)	Cos	Weight (kg)
4A C46 (H/V)	0,60/0,20	1,49/0,75	0,82/0,64	110
4A D46 (H/V)	0,75/0,22	2,13/1,0	0,81/0,71	110
4A E46 (H/V)	1,00/0,30	3,12/1,2	0,79/0,70	115
4A F46 (H/V)	1,50/0,44	3,74/1,6	0,81/0,72	115
4A G46 (H/V)	2,20/0,65	5,5/2,5	0,80/0,73	120
4A H46 (H/V)	3,00/1,00	6,73/3,1	0,82/0,68	125
4A I46 (H/V)	4,20/1,25	9,2/5,1	0,86/0,67	150

The **250** and **200** dynamic pressures are the maximum pressures recommended for acceptable acoustic levels in comfort/smoke extraction applications.



## PYROSTAR® 4R

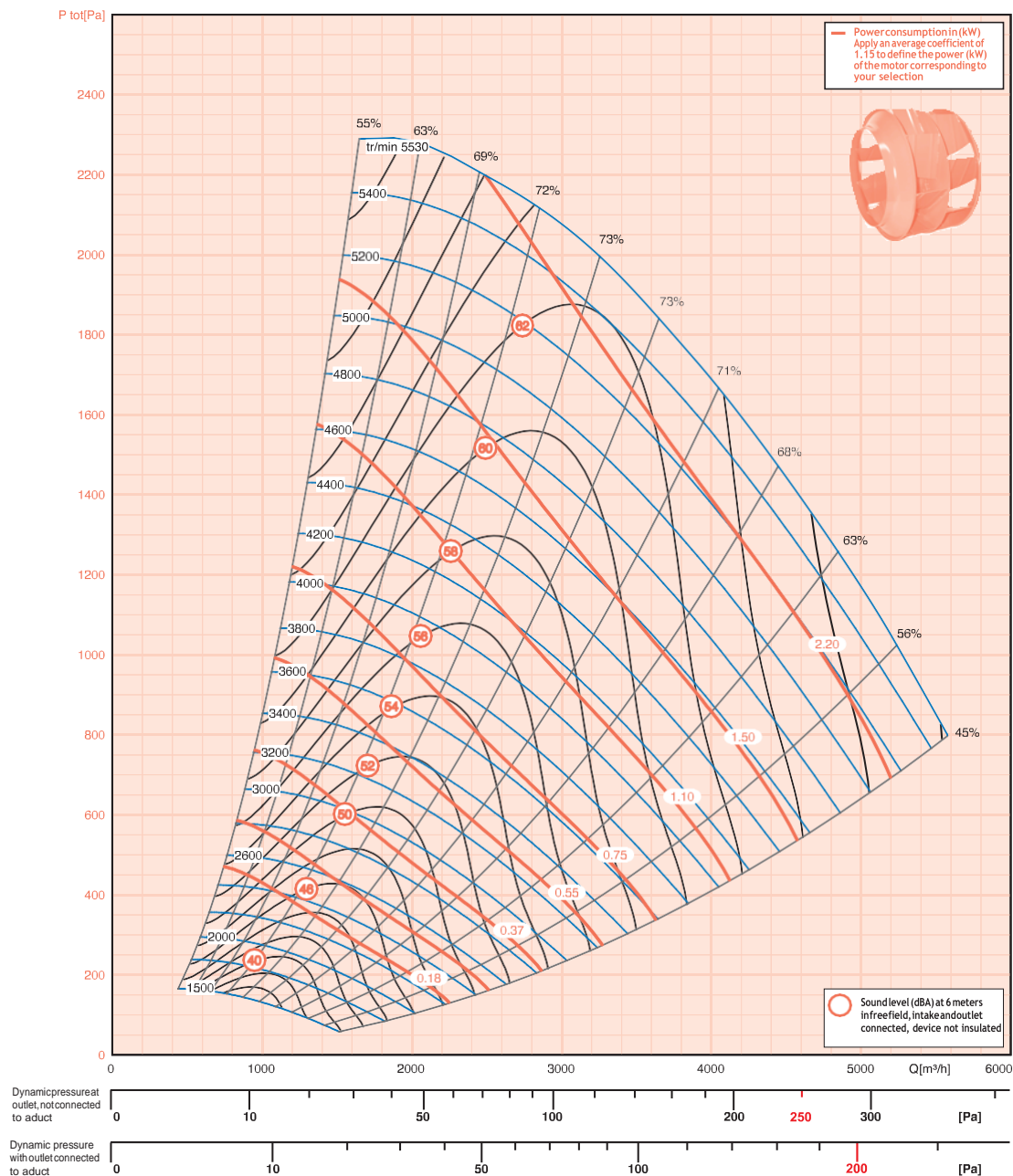

Motor 1 speed 400 V three-phase 50 Hz 2 and 4 poles	PYROSTAR® Model	P.motor	Int. Cos	Weight
4R B2 (H/V)		0,37	0,97	0,79 100
4R B4 (H/V)		0,37	1,10	0,76 100
4R C2 (H/V)		0,55	1,4	0,80 100
4R D2 (H/V)		0,75	1,80	0,81 100
4R E2 (H/V)		1,10	2,40	0,83 105
4R F2 (H/V)		1,50	3,30	0,83 105
4R G2 (H/V)		2,20	4,5	0,86 110
4R H2 (H/V)		3,00	5,90	0,87 115

Motor 2 speed 400 V three-phase - 50 Hz 2/4 and 4/8 poles Dahlander	PYROSTAR® Model	Motor pwr. (kW)	Rated current (A)	Cos	Weight (kg)
4R B24 (H/V)		0,37/0,08	0,9/0,25	0,92/0,81	100
4R B48 (H/V)		0,37/0,09	1,32/0,5	0,71/0,62	100
4R E24 (H/V)		1,10/0,25	2,51/1,05	0,85/0,70	115
4R F24 (H/V)		1,50/0,33	3,5/1,27	0,89/0,71	115
4R G24 (H/V)		2,20/0,45	4,6/1,72	0,88/0,64	115
4R H24 (H/V)		3,00/0,60	6,2/1,91	0,90/0,74	130

Motor 2 speed 400 V three-phase - 50 Hz 4/6 poles separate windings	PYROSTAR® Model	Motor pwr. (kW)	Rated current (A)	Cos	Weight (kg)
4R B46 (H/V)		0,50/0,19	1,4/0,7	0,89/0,79	100

The **250** and **200** dynamic pressures are the maximum pressures recommended for acceptable acoustic levels in comfort/smoke extraction applications.



PYROSTAR® 6A

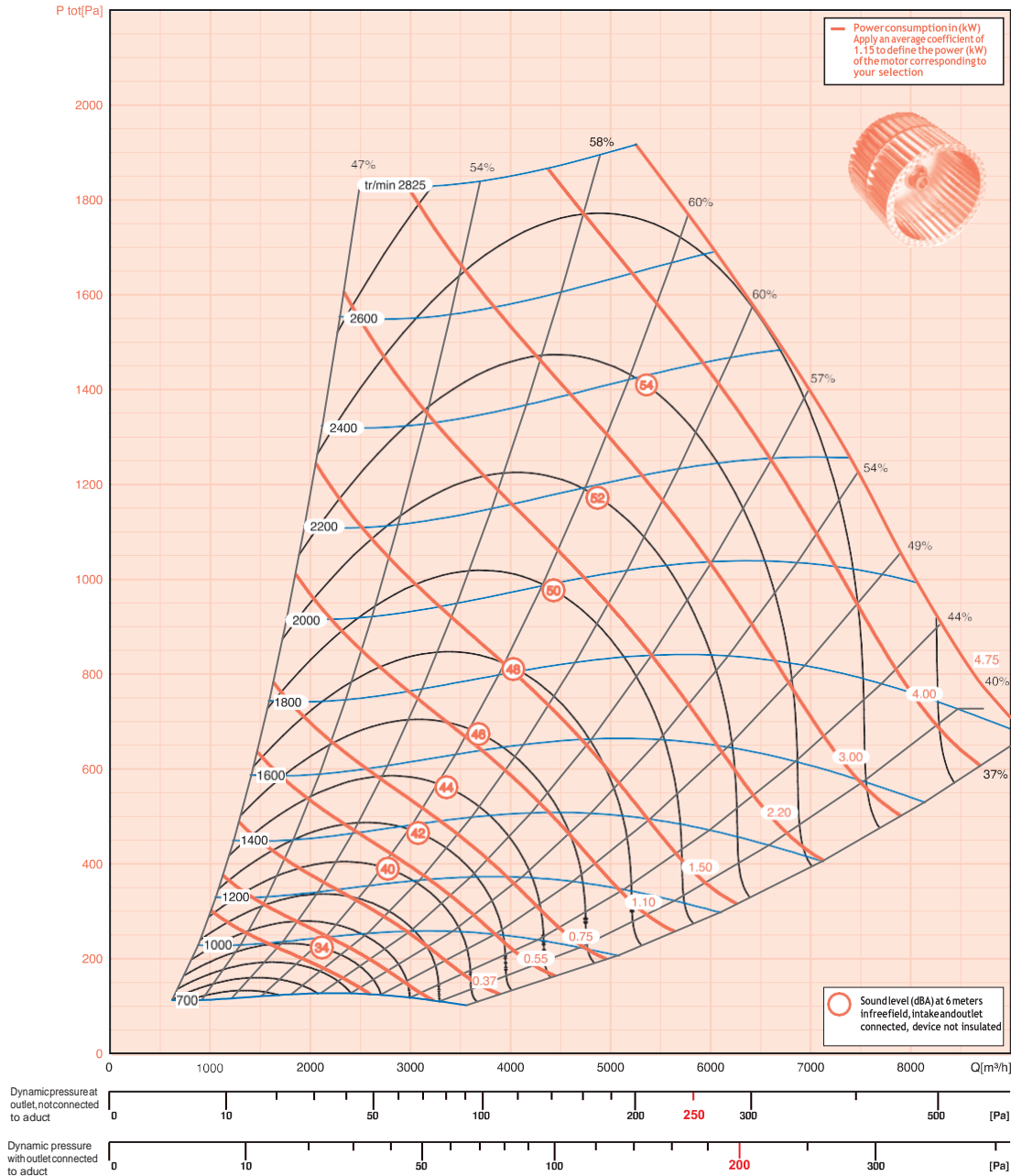

Motor 1 speed 400 V three-phase 50 Hz 2 and 4 poles	PYROSTAR® Model	Mo.pwr. (kW)	Rated current (A)	Cos	Weight (kg)
6A B4 (H/V)		0,37	1,10	0,76	105
6A C4 (H/V)		0,55	1,60	0,76	105
6A D4 (H/V)		0,75	1,90	0,73	105
6A E4 (H/V)		1,10	2,6	0,79	115
6A F4 (H/V)		1,50	3,4	0,73	120
6A G2 (H/V)		2,20	4,5	0,86	140
6A G4 (H/V)		2,20	4,9	0,79	140
6A H2 (H/V)		3,00	5,9	0,87	135
6A H4 (H/V)		3,00	6,5	0,79	135
6A I2 (H/V)		4,00	7,70	0,88	140
6A I4 (H/V)		4,00	8,60	0,79	140
6A J2 (H/V)		5,50	11,00	0,85	150
6A J4 (H/V)		5,50	11,10	0,80	150

Motor 2 speed 400 V three-phase-50Hz 2/4 and 4/8 poles Dahlander	PYROSTAR® Model	Motor pwr. (kW)	Rated current (A)	Cos	Weight (kg)
6A B48 (H/V)		0,37/0,09	1,32/0,5	0,71/0,62	105
6A C48 (H/V)		0,55/0,13	1,8/0,91	0,71/0,62	110
6AD48 (H/V)		0,75/0,17	2,1/1,02	0,78/0,63	110
6A E48 (H/V)		1,10/0,26	2,9/1,51	0,79/0,61	115
6A F48 (H/V)		1,50/0,35	4/1,81	0,81/0,60	120
6A G24 (H/V)		2,20/0,45	4,6/1,72	0,88/0,64	135
6A G48 (H/V)		2,20/0,50	5,2/2,6	0,81/0,58	135
6AH24 (H/V)		3,00/0,60	6,2/1,91	0,90/0,74	140
6AH48 (H/V)		3,00/0,65	6,8/3	0,81/0,57	140
6A I24 (H/V)		4,00/1,00	8,4/2,58	0,92/0,78	140
6A I48 (H/V)		4,00/1,00	8,6/3,5	0,83/0,60	140
6A J24 (H/V)		5,50/1,30	11,3/3,5	0,91/0,76	155
6A J48 (H/V)		5,50/1,37	11,4/4,5	0,84/0,60	155

Motor 2 speed 400 V three-phase-50Hz 4/6 poles separate windings	PYROSTAR® Model	Motor pwr. (kW)	Rated current (A)	Cos	Weight (kg)
6A C46 (H/V)		0,60/0,20	1,49/0,75	0,82/0,64	105
6A D46 (H/V)		0,75/0,22	2,13/1,0	0,81/0,71	110
6A E46 (H/V)		1,00/0,30	3,12/1,2	0,79/0,70	115
6A F46 (H/V)		1,50/0,44	3,74/1,6	0,81/0,72	120
6A G46 (H/V)		2,20/0,65	5,5/2,5	0,80/0,73	120
6A H46 (H/V)		3,00/1,00	6,73/3,1	0,82/0,68	130
6A I46 (H/V)		4,20/1,25	9,2/5,1	0,86/0,67	150
6A J46 (H/V)		5,50/1,60	12/5,6	0,84/0,72	165

The 250 and 200 dynamic pressures are the maximum pressures recommended for acceptable acoustic levels in comfort/smoke extraction applications.





PYROSTAR® 6R

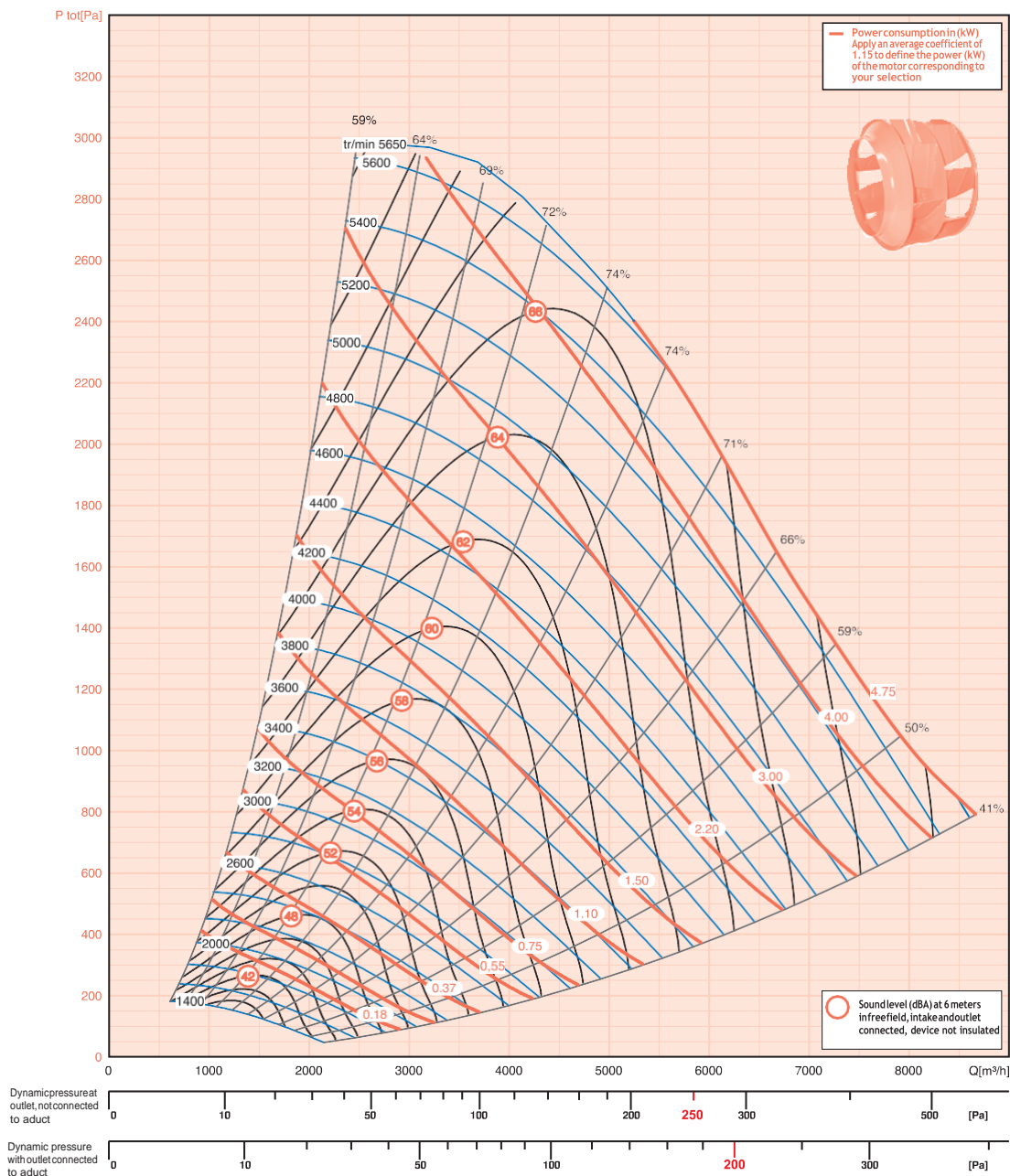

Motor 1 speed 400 V three-phase 50 Hz 2 and 4 poles

PYROSTAR® Model	Mo. pwr. (kW)	Rated current (A)	Cos	Weight (kg)
6R B4 (H/V)	0,37	1,10	0,75	110
6R C2 (H/V)	0,55	1,42	0,79	110
6R C4 (H/V)	0,55	1,60	0,76	110
6R D2 (H/V)	0,75	1,80	0,75	110
6R D4 (H/V)	0,75	1,90	0,74	110
6R E2 (H/V)	1,10	2,40	0,82	115
6R F2 (H/V)	1,50	3,30	0,84	115
6R G2 (H/V)	2,20	4,40	0,88	120
6R H2 (H/V)	3,00	5,80	0,88	125
6R I2 (H/V)	4,00	7,70	0,89	130
6R J2 (H/V)	5,50	11,00	0,87	145

Motor 2 speed 400 V three-phase -50Hz 2/4 and 4/8 poles Dahlander

PYROSTAR® Model	Motor pwr. (kW)	Rated current (A)	Cos	Weight (kg)
6R B48 (H/V)	0,37/0,09	1,32/0,5	0,71/0,62	110
6R C48 (H/V)	0,55/0,13	1,8/0,91	0,71/0,62	115
6R D48 (H/V)	0,75/0,17	2,1/1,02	0,78/0,63	115
6R E24 (H/V)	1,10/0,25	2,51/1,05	0,85/0,70	120
6R F24 (H/V)	1,50/0,33	3,5/1,27	0,89/0,71	125
6R G24 (H/V)	2,20/0,45	4,6/1,72	0,88/0,64	125
6R H24 (H/V)	3,00/0,60	6,2/1,91	0,90/0,74	140
6R I24 (H/V)	4,00/1,00	8,4/2,58	0,92/0,78	140
6R J24 (H/V)	5,50/1,30	11,3/3,5	0,91/0,76	160

Motor 2 speed 400 V three-phase -50Hz 4/6 poles separate windings

PYROSTAR® Model	Motor pwr. (kW)	Rated current (A)	Cos	Weight (kg)
6R C46 (H/V)	0,60/0,20	1,49/0,75	0,82/0,64	110
6R D46 (H/V)	0,75/0,22	2,13/1,0	0,81/0,71	115

The 250 and 200 dynamic pressures are the maximum pressures recommended for acceptable acoustic levels in comfort/smoke extraction applications.



PYROSTAR® 10A

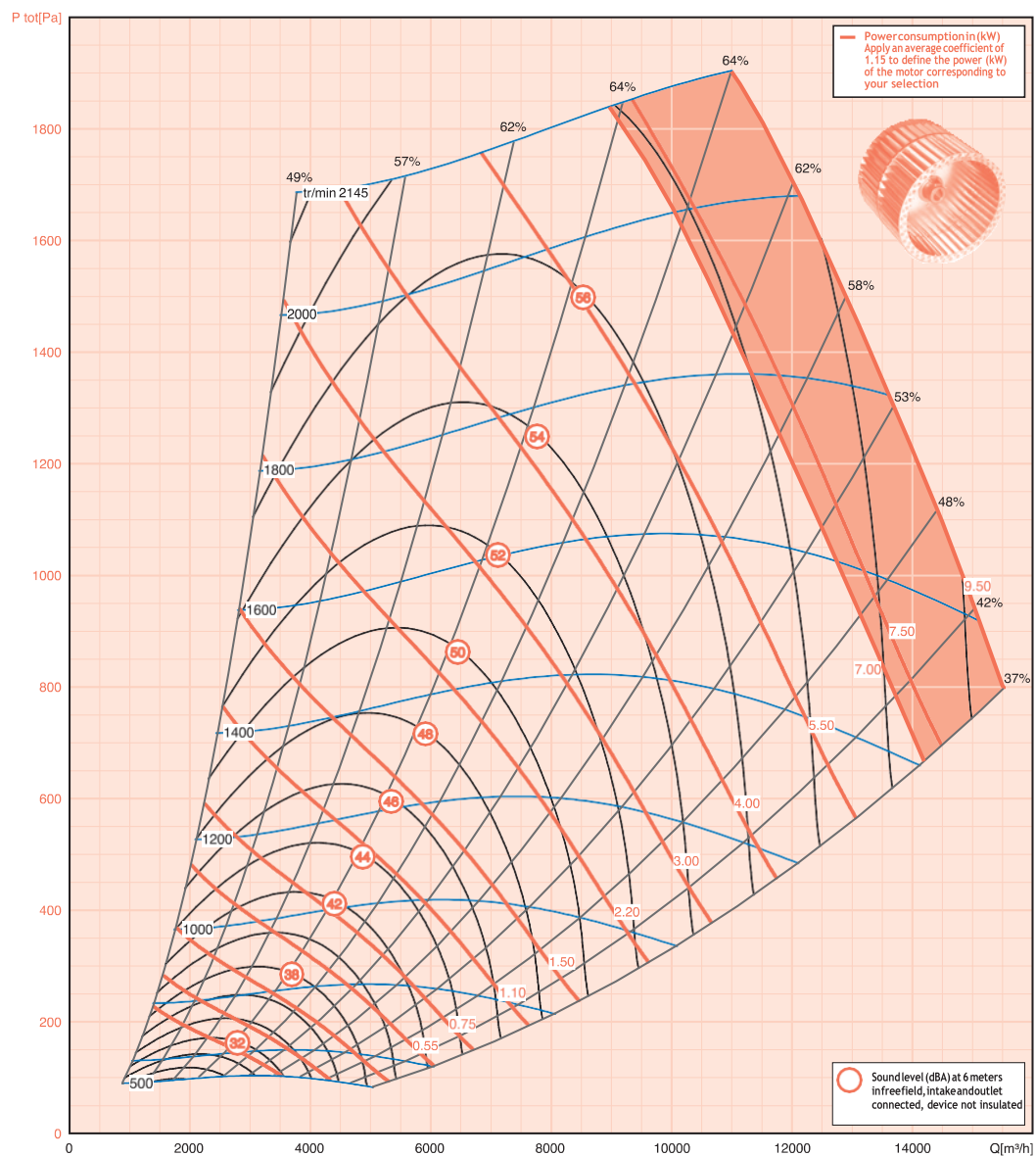

Smoke extraction only

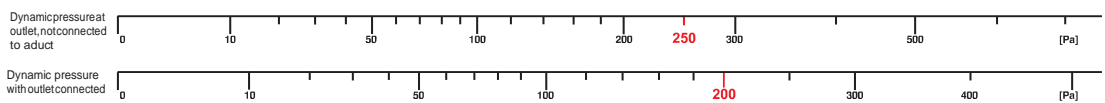

Motor 1 speed 400 V three-phase 50 Hz 2 and 4 poles				Motor 2 speed 400 V three-phase - 50Hz 2/4 and 4/8 poles Dahlander				Motor 2 speed 400 V three-phase - 50Hz 4/6 poles separate windings						
PYROSTAR® Model	Mo. pwr. (kW)	Rated current (A)	Rated Cos	Weight (kg)	PYROSTAR® Model	Motor pwr. (kW)	Rated current (A)	Rated Cos	Weight (kg)	PYROSTAR® Model	Motor pwr. (kW)	Rated current (A)	Rated Cos	Weight (kg)
10A C4 (H/V)	0,55	1,60	0,76	170	10A C48 (H/V)	0,55/0,13	1,8/0,91	0,71/0,62	170	10A C46 (H/V)	0,60/0,20	1,49/0,75	0,82/0,64	170
10A D4 (H/V)	0,75	1,90	0,74	170	10A D48 (H/V)	0,75/0,17	2,1/1,02	0,78/0,63	170	10A D46 (H/V)	0,75/0,22	2,13/1,0	0,81/0,71	170
10A E4 (H/V)	1,10	2,72	0,78	170	10A E48 (H/V)	1,10/0,26	2,9/1,51	0,79/0,61	175	10A E46 (H/V)	1,00/0,30	3,12/1,2	0,79/0,70	175
10A F4 (H/V)	1,50	3,65	0,74	175	10A F48 (H/V)	1,50/0,35	4/1,81	0,81/0,60	180	10A F46 (H/V)	1,50/0,44	3,74/1,6	0,81/0,72	180
10A G4 (H/V)	2,20	5,00	0,76	180	10A G48 (H/V)	2,20/0,50	5,2/2,6	0,81/0,58	180	10A G46 (H/V)	2,20/0,65	5,5/2,5	0,80/0,73	180
10A H4 (H/V)	3,00	6,52	0,77	180	10A H48 (H/V)	3,00/0,65	6,8/3	0,81/0,57	205	10A H46 (H/V)	3,00/1,00	6,73/3,1	0,82/0,68	200
10A I4 (H/V)	4,00	8,90	0,78	190	10A I48 (H/V)	4,00/1,00	8,6/3,5	0,83/0,60	215	10A I46 (H/V)	4,20/1,25	9,2/5,1	0,86/0,67	230
10A J4 (H/V)	5,50	11,30	0,82	200	10A J48 (H/V)	5,50/1,37	11,4/4,5	0,84/0,60	215	10A J46 (H/V)	5,50/1,60	12/5,6	0,84/0,72	235
10A K4 (H/V)	7,50	15,00	0,83	210	10A K48 (H/V)	7,50/1,87	15,2/6,6	0,83/0,59	225	10A K46 (H/V)	7,50/2,20	14,65/5,8	0,86/0,73	255
10A L4 (H/V)	9,00	19,00	0,77	220	10A L48 (H/V)	9,00/2,20	16,7/9,64	0,84/0,54	235	10A M46 (H/V)	10,50/3,30	21,4/8,6	0,85/0,77	285
10A M4 (H/V)	11,00	22,20	0,82	240	10A M48 (H/V)	11,00/2,70	22,63/8,6	0,82/0,58	255					

The 250 and 200 dynamic pressures are the maximum pressures recommended for acceptable acoustic levels in comfort/smoke extraction applications.



PYROSTAR® 10R

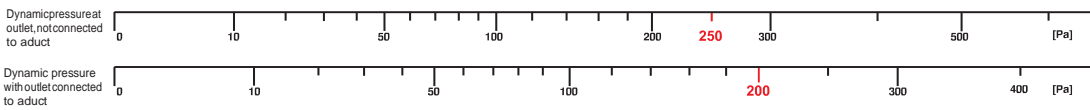
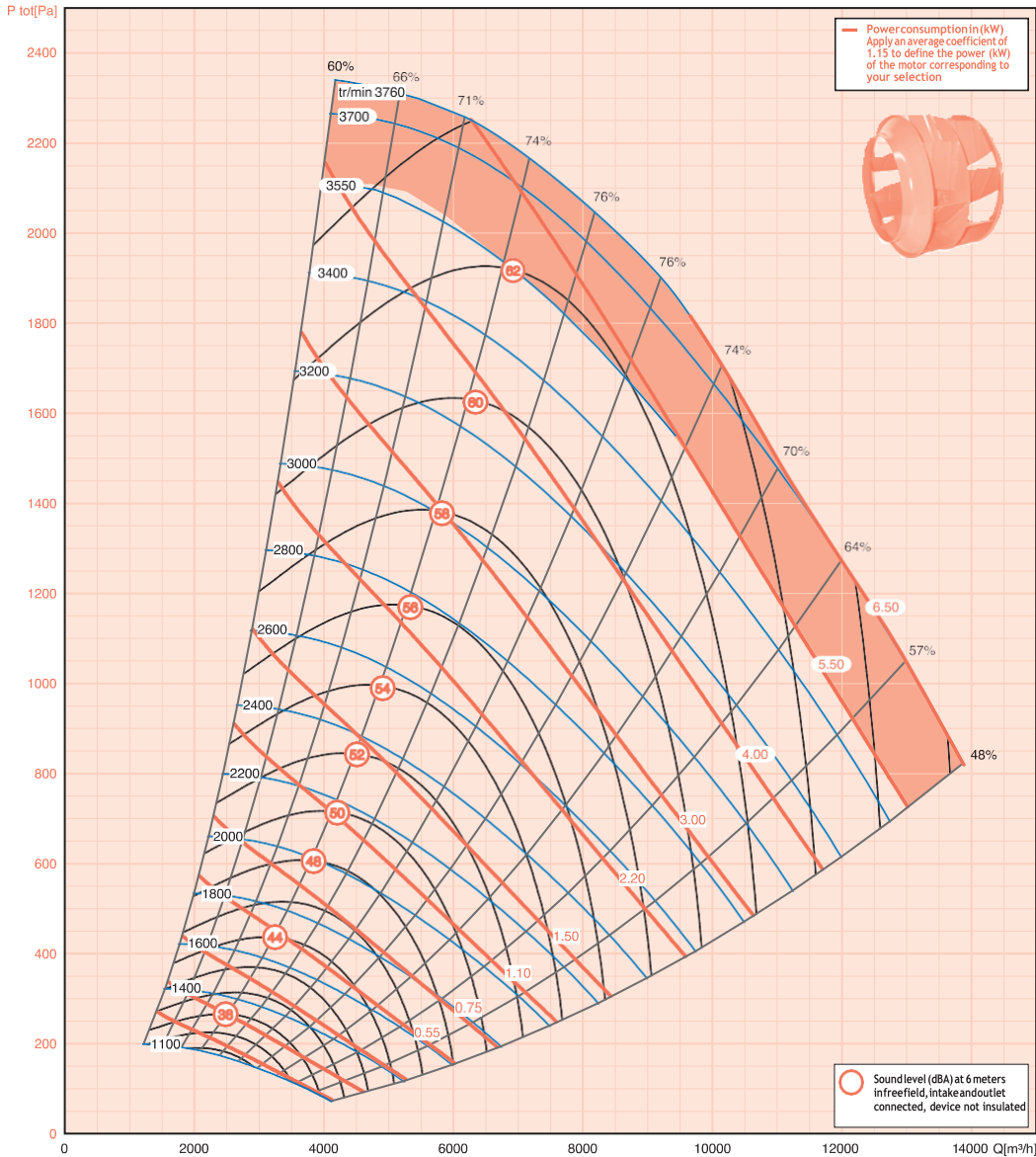

Motor 1 speed 400 V three-phase 50 Hz 2 and 4 poles

PYROSTAR® Model	Mo.pwr. (kW)	Rated current (A)	Cos	Weight (kg)
10R C4 (H/V)	0,55	1,60	0,76	170
10R D4 (H/V)	0,75	1,90	0,73	170
10R E4 (H/V)	1,10	2,72	0,79	170
10R F2 (H/V)	1,50	3,30	0,83	175
10R F4 (H/V)	1,50	3,65	0,73	175
10R G2 (H/V)	2,20	4,40	0,86	180
10R G4 (H/V)	2,20	5,00	0,79	180
10R H2 (H/V)	3,00	5,80	0,87	180
10R I2 (H/V)	4,00	7,70	0,88	190
10R J2 (H/V)	5,50	11,00	0,85	200
10R K2 (H/V)	7,50	14,10	0,89	210

Motor 2 speed 400 V three-phase - 50 Hz 2/4 and 4/8 poles Dahlander

PYROSTAR® Model	Motor pwr. (kW)	Rated current (A)	Cos	Weight (kg)
10R C48 (H/V)	0,55/0,13	1,8/0,91	0,71/0,62	170
10R D48 (H/V)	0,75/0,17	2,1/1,02	0,78/0,63	170
10R E48 (H/V)	1,10/0,26	2,9/1,51	0,79/0,61	175
10R F24 (H/V)	1,50/0,33	3,5/1,27	0,89/0,71	180
10R F48 (H/V)	1,50/0,35	4/1,81	0,81/0,60	180
10R G24 (H/V)	2,20/0,45	4,6/1,72	0,88/0,64	180
10R G48 (H/V)	2,20/0,50	5,2/2,6	0,81/0,58	180
10R H24 (H/V)	3,00/0,60	6,2/1,91	0,90/0,74	205
10R I24 (H/V)	4,00/1,00	8,4/2,58	0,92/0,78	215
10R J24 (H/V)	5,50/1,30	11,3/3,5	0,91/0,76	215
10R K24 (H/V)	7,50/1,87	14,8/3,6	0,91/0,89	225

Motor 2 speed 400 V three-phase - 50 Hz 4/6 poles separate windings

PYROSTAR® Model	Motor pwr. (kW)	Rated current (A)	Cos	Weight (kg)
10R C46 (H/V)	0,60/0,20	1,49/0,75	0,82/0,64	170
10R D46 (H/V)	0,75/0,22	2,13/1,0	0,81/0,71	170
10R E46 (H/V)	1,00/0,30	3,12/1,2	0,79/0,70	175
10R F46 (H/V)	1,50/0,44	3,74/1,6	0,81/0,72	180
10R G46 (H/V)	2,20/0,65	5,5/2,5	0,80/0,73	180

The 250 and 200 dynamic pressures are the maximum pressures recommended for acceptable acoustic levels in comfort/smoke extraction applications.



PYROSTAR® 12A

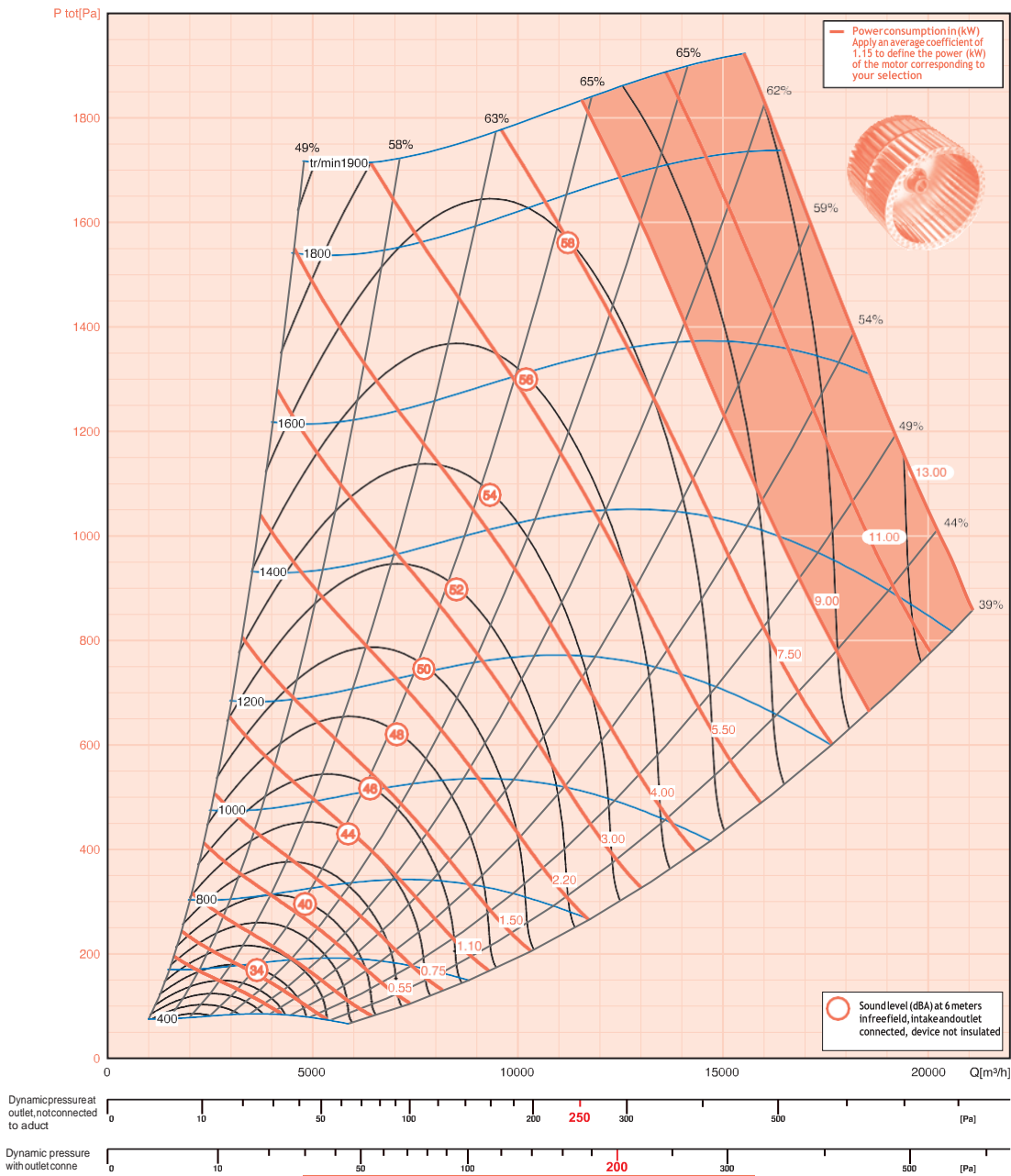

Smoke extraction only

Motor 1 speed 400 V three-phase 50 Hz 2 and 4 poles			
PYROSTAR® Model	Mo. pwr. (kW)	Rated current (A)	Cos Weight (kg)
12A C4 (H/V)	0,55	1,60	0,76 165
12A D4 (H/V)	0,75	1,90	0,74 170
12A E4 (H/V)	1,10	2,72	0,78 175
12A F4 (H/V)	1,50	3,65	0,74 175
12A G4 (H/V)	2,20	5,00	0,76 180
12A H4 (H/V)	3,00	6,52	0,77 185
12A I4 (H/V)	4,00	8,90	0,78 185
12A J4 (H/V)	5,50	11,30	0,82 225
12A K4 (H/V)	7,50	15,00	0,83 235
12A L4 (H/V)	9,00	19,00	0,77 245
12A M4 (H/V)	11,00	22,20	0,82 265
12A N4 (H/V)	15,00	28,80	0,82 285

Motor 2 speed 400 V three-phase - 50 Hz 2/4 and 4/8 poles Dahlander			
PYROSTAR® Model	Motor pwr. (kW)	Rated current (A)	Cos Weight (kg)
12A C48 (H/V)	0,55/0,13	1,8/0,91	0,71/0,62 180
12A D48 (H/V)	0,75/0,17	2,1/1,02	0,78/0,63 180
12A E48 (H/V)	1,10/0,26	2,9/1,51	0,79/0,61 185
12A F48 (H/V)	1,50/0,35	4/1,81	0,81/0,60 190
12A G48 (H/V)	2,20/0,50	5,2/2,6	0,81/0,58 190
12A H48 (H/V)	3,00/0,65	6,8/3	0,81/0,57 205
12A I48 (H/V)	4,00/1,00	8,6/3,5	0,83/0,60 205
12A J48 (H/V)	5,50/1,37	11,4/4,5	0,84/0,60 225
12A K48 (H/V)	7,50/1,87	15,2/6,6	0,83/0,59 235
12A L48 (H/V)	9,00/2,20	16,7/9,64	0,84/0,54 235
12A M48 (H/V)	11,00/2,70	22,63/8,6	0,82/0,58 255
12A N48 (H/V)	15,00/2,70	30/10,9	0,86/0,59 275

Motor 2 speed 400 V three-phase - 50 Hz 4/6 poles separate windings			
PYROSTAR® Model	Motor pwr. (kW)	Rated current (A)	Cos Weight (kg)
12A C46 (H/V)	0,60/0,20	1,49/0,75	0,82/0,64 175
12A D46 (H/V)	0,75/0,22	2,13/1,0	0,81/0,71 180
12A E46 (H/V)	1,00/0,30	3,12/1,2	0,79/0,70 185
12A F46 (H/V)	1,50/0,44	3,74/1,6	0,81/0,72 185
12A G46 (H/V)	2,20/0,65	5,5/2,5	0,80/0,73 190
12A H46 (H/V)	3,00/1,00	6,73/3,1	0,82/0,68 195
12A I46 (H/V)	4,20/1,25	9,2/5,1	0,86/0,67 225
12A J46 (H/V)	5,50/1,60	12/5,6	0,84/0,72 235
12A K46 (H/V)	7,50/2,20	14,65/5,8	0,86/0,73 255
12A M46 (H/V)	10,50/3,30	21,4/8,6	0,85/0,77 275
12A N46 (H/V)	14,5/4,40	28,1/11	0,86/0,75 295

The 250 and 200 dynamic pressures are the maximum pressures recommended for acceptable acoustic levels in comfort/smoke extraction applications.



## PYROSTAR® 12R

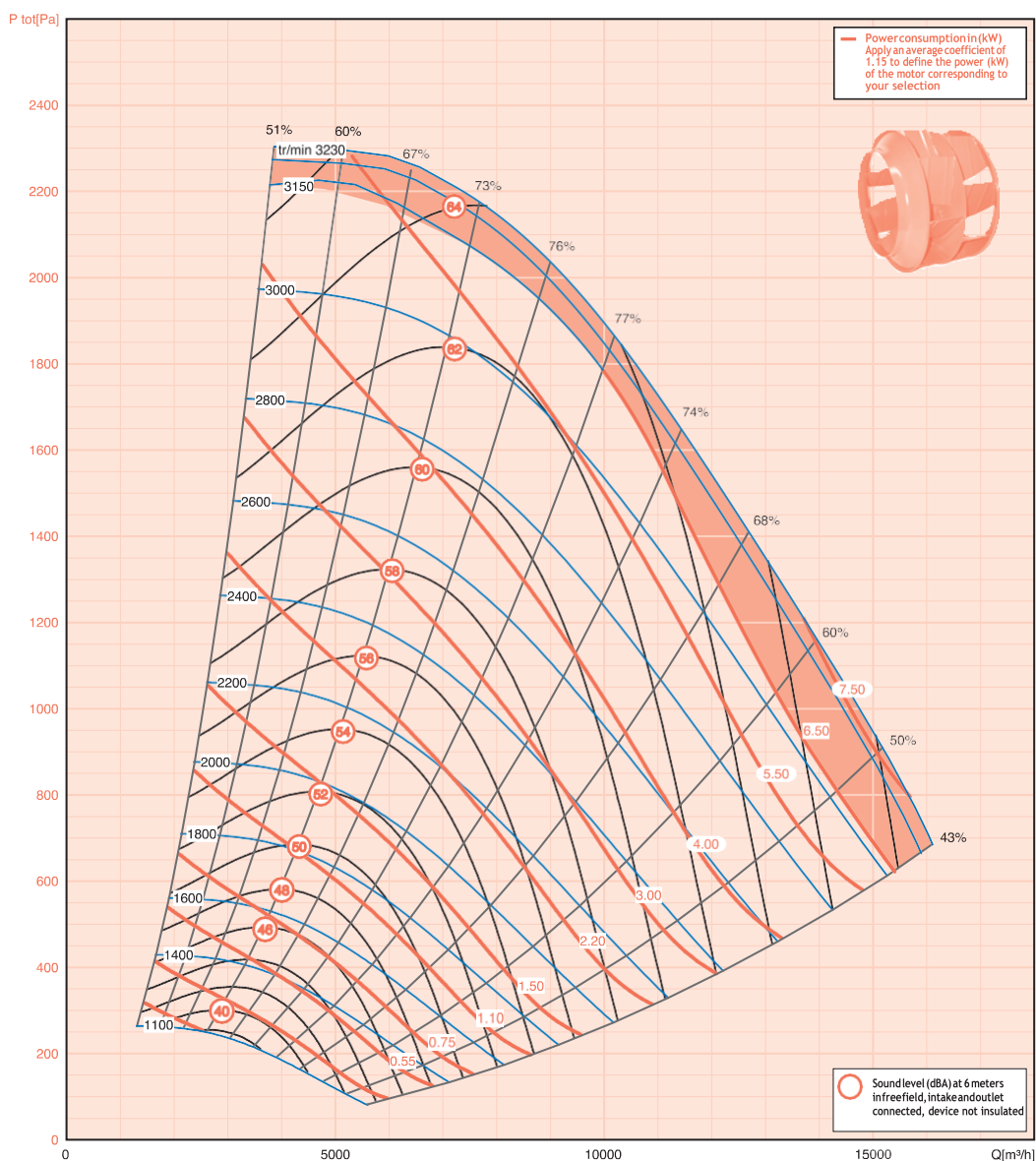

Smoke extraction only

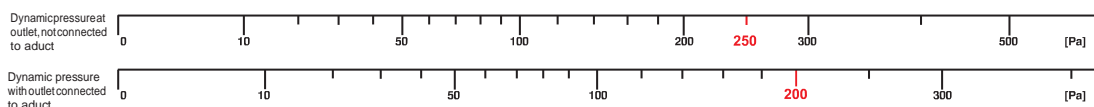

Motor 1 speed 400 V three-phase 50 Hz 2 and 4 poles			
PYROSTAR® Model	Mo.pwr. (kW)	Rated current (A)	Weight (kg)
12R D4 (H/V)	0,75	1,90	0,74 180
12R E4 (H/V)	1,10	2,72	0,78 180
12R F4 (H/V)	1,50	3,65	0,74 185
12R G2 (H/V)	2,20	4,40	0,88 190
12R G4 (H/V)	2,20	5,00	0,76 190
12R H2 (H/V)	3,00	5,80	0,88 195
12R H4 (H/V)	3,00	6,52	0,77 195
12R I2 (H/V)	4,00	7,70	0,89 205
12R I4 (H/V)	4,00	8,90	0,78 205
12R J2 (H/V)	5,50	11,00	0,87 225
12R J4 (H/V)	5,50	11,30	0,82 225
12R K2 (H/V)	7,50	14,10	0,88 235
12R L2 (H/V)	9,00	17,00	0,86 245

Motor 2 speed 400 V three-phase-50Hz 2/4 and 4/8 poles Dahlander			
PYROSTAR® Model	Motor pwr. (kW)	Rated current (A)	Cos Weight (kg)
12R D48 (H/V)	0,75/0,17	2,1/1,02	0,78/0,63 185
12R E48 (H/V)	1,10/0,26	2,9/1,51	0,79/0,61 190
12R F48 (H/V)	1,50/0,35	4/1,81	0,81/0,60 195
12R G24 (H/V)	2,20/0,45	4,6/1,72	0,88/0,64 195
12R G48 (H/V)	2,20/0,50	5,2/2,6	0,81/0,58 195
12R H24 (H/V)	3,00/0,60	6,2/1,91	0,90/0,74 195
12R H48 (H/V)	3,00/0,65	6,8/3	0,81/0,57 210
12R I24 (H/V)	4,00/1,00	8,4/2,58	0,92/0,78 210
12R I48 (H/V)	4,00/1,00	8,6/3,5	0,83/0,60 210
12R J24 (H/V)	5,50/1,30	11,3/3,5	0,91/0,76 230
12R J48 (H/V)	5,50/1,37	11,4/4,5	0,84/0,60 230
12R K24 (H/V)	7,50/1,87	14,8/3,6	0,91/0,89 240
12R L24 (H/V)	9,00/2,20	13,0/7,4	0,93/0,80 240

Motor 2 speed 400 V three-phase-50Hz 4/6 poles separate windings			
PYROSTAR® Model	Motor pwr. (kW)	Rated current (A)	Cos Weight (kg)
12R D46 (H/V)	0,75/0,22	2,13/1,0	0,81/0,71 185
12R E46 (H/V)	1,00/0,30	3,12/1,2	0,79/0,70 190
12R F46 (H/V)	1,50/0,44	3,74/1,6	0,81/0,72 190
12R G46 (H/V)	2,20/0,65	5,5/2,5	0,80/0,73 195
12R H46 (H/V)	3,00/1,00	6,73/3,1	0,82/0,68 200
12R I46 (H/V)	4,20/1,25	9,2/5,1	0,86/0,67 230
12R J46 (H/V)	5,50/1,60	12/5,6	0,84/0,72 240

The **250** and **200** dynamic pressures are the maximum pressures recommended for acceptable acoustic levels in comfort/smoke extraction applications.

3 SMOKE EXTRACTION

SELECTION CURVES

# PYROSTAR®

## PYROSTAR® 15A

**Power consumption in (kW)**  
Apply an average coefficient of 1.15 to define the power (kW) of the motor corresponding to your selection

**Sound level (dBA) at 6 meters in freefield, intake and outlet connected, device not insulated**

Smoke extraction only

Dynamic pressure at outlet, not connected to aduct: 0, 10, 50, 100, 200, 250, 300, 500, [Pa]

Dynamic pressure with outlet connected to aduct: 0, 10, 50, 100, 200, 300, 400, [Pa]

Motor 1 speed 400 V three-phase 50 Hz 2 and 4 poles					Motor 2 speed 400 V three-phase -50Hz 2/4 and 4/8 poles Dahlander					Motor 2 speed 400 V three-phase -50Hz 4/6 poles separate windings				
PYROSTAR® Model	Mo.pwr. (kW)	Rated current (A)	Cos	Weight (kg)	PYROSTAR® Model	Motor pwr. (kW)	Rated current (A)	Cos	Weight (kg)	PYROSTAR® Model	Motor pwr. (kW)	Rated current (A)	Cos	Weight (kg)
15A D4 (H/V)	0,75	1,90	0,74	255	15A D48 (H/V)	0,75/0,17	2,1/1,02	0,78/0,63	255	15A D46 (H/V)	0,75/0,22	2,13/1,0	0,81/0,71	265
15A E4 (H/V)	1,10	2,72	0,78	255	15A E48 (H/V)	1,10/0,26	2,9/1,51	0,79/0,61	265	15A E46 (H/V)	1,00/0,30	3,12/1,2	0,79/0,70	265
15A F4 (H/V)	1,50	3,65	0,74	265	15A F48 (H/V)	1,50/0,35	4/1,81	0,81/0,60	265	15A F46 (H/V)	1,50/0,44	3,74/1,6	0,81/0,72	265
15A G4 (H/V)	2,20	5,00	0,76	265	15A G48 (H/V)	2,20/0,50	5,2/2,6	0,81/0,58	265	15A G46 (H/V)	2,20/0,65	5,5/2,5	0,80/0,73	265
15A H4 (H/V)	3,00	6,52	0,77	265	15A H48 (H/V)	3,00/0,65	6,8/3	0,81/0,57	285	15A H46 (H/V)	3,00/1,00	6,73/3,1	0,82/0,68	275
15A I4 (H/V)	4,00	8,90	0,78	275	15A I48 (H/V)	4,00/1,00	8,6/3,5	0,83/0,60	285	15A I46 (H/V)	4,20/1,25	9,2/5,1	0,86/0,67	305
15A J4 (H/V)	5,50	11,30	0,82	285	15A J48 (H/V)	5,50/1,37	11,4/4,5	0,84/0,60	305	15A J46 (H/V)	5,50/1,60	12/5,6	0,84/0,72	315
15A K4 (H/V)	7,50	15,00	0,83	295	15A K48 (H/V)	7,50/1,87	15,2/6,6	0,83/0,59	315	15A K46 (H/V)	7,50/2,20	14,65/5,8	0,86/0,73	335
15A L4 (H/V)	9,00	19,00	0,77	305	15A L48 (H/V)	9,00/2,20	16,7/9,64	0,84/0,54	325	15A M46 (H/V)	10,50/3,30	21,4/8,6	0,85/0,77	345
15A M4 (H/V)	11,00	22,20	0,82	335	15A M48 (H/V)	11,00/2,70	22,63/8,6	0,82/0,58	325	15A N46 (H/V)	14,5/4,40	28,1/11	0,86/0,75	365
15A N4 (H/V)	15,00	28,80	0,82	355	15A N48 (H/V)	15,00/2,70	30/10,9	0,86/0,59	355					

The **250** and **200** dynamic pressures are the maximum pressures recommended for acceptable acoustic levels in comfort/smoke extraction applications.

P280 CALADAIR | 61 rue de Saint Véran | 71000 MÂCON LOCHÉ | Tél. 33 (0)3 85 36 82 00 – Fax 33 (0)3 85 36 82 01 | www.caladair.com



## PYROSTAR® 15R

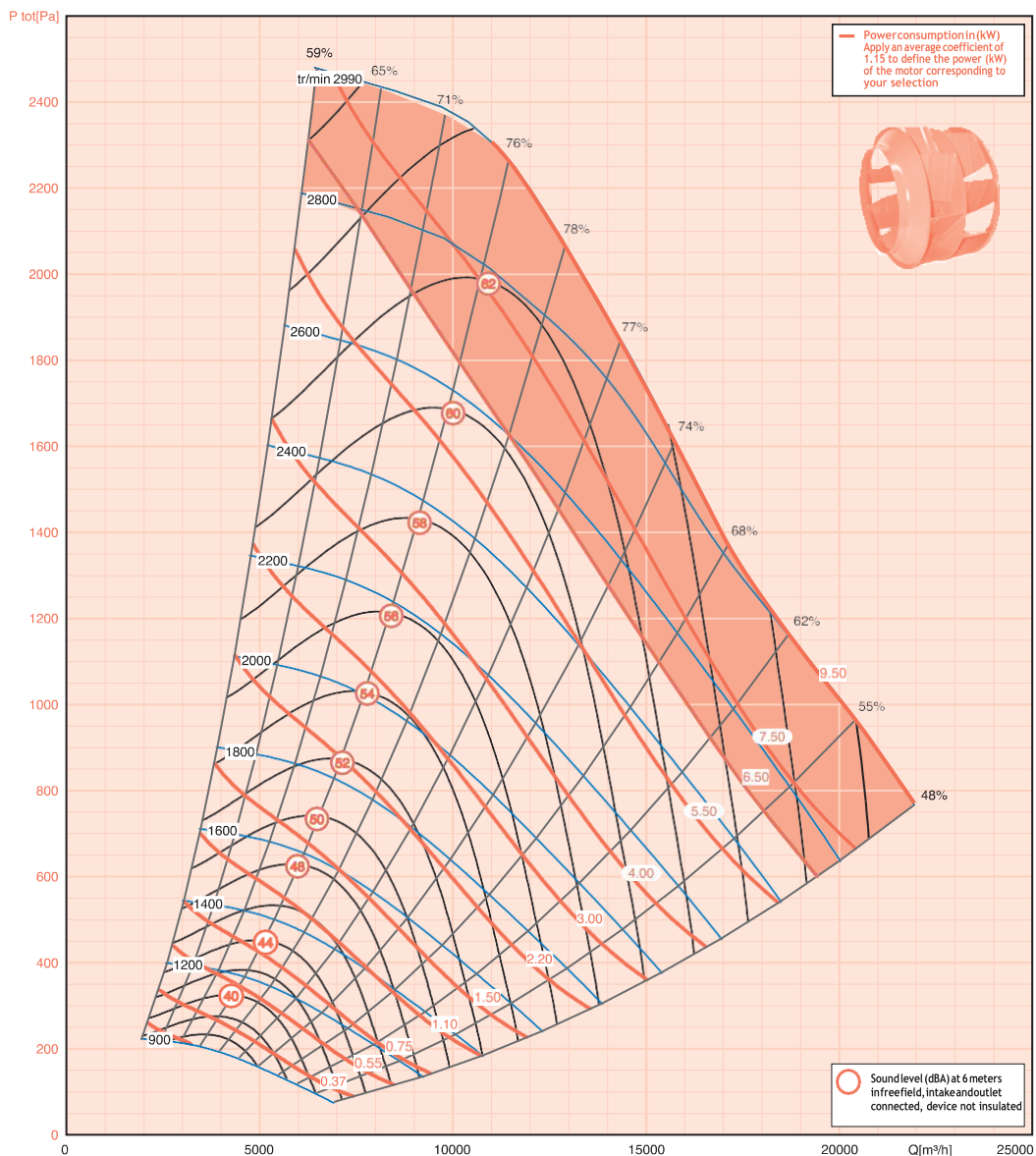

Smoke extraction only

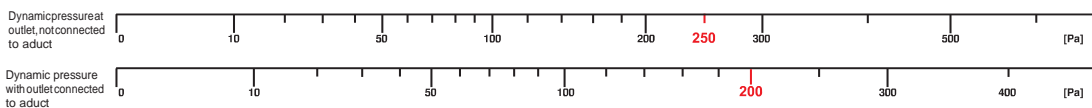

Motor 1 speed 400 V three-phase 50 Hz 2 and 4 poles

PYROSTAR® Mo.pwr. Rated Cos Weight  
Model (kW) current (A) (kg)

15R E4 (H/V)	1,10	2,72	0,78	260
15R F4 (H/V)	1,50	3,65	0,74	270
15R G4 (H/V)	2,20	5,00	0,76	270
15R H4 (H/V)	3,00	6,52	0,77	270
15R I2 (H/V)	4,00	7,70	0,89	270
15R I4 (H/V)	4,00	8,90	0,78	280
15R J2 (H/V)	5,50	11,00	0,87	280
15R J4 (H/V)	5,50	11,30	0,82	290
15R K2 (H/V)	7,50	14,10	0,88	290
15R K4 (H/V)	7,50	15,00	0,83	300
15R L2 (H/V)	9,00	17,00	0,86	300
15R L4 (H/V)	9,00	19,00	0,77	310
15R M2 (H/V)	11,00	20,20	0,90	310

Motor 2 speed 400 V three-phase-50 Hz 2/4 and 4/8 poles Dahlander

PYROSTAR® Motor pwr. Rated Cos Weight  
Model (kW) current (A) (kg)

15R E48 (H/V)	1,10/0,26	2,9/1,51	0,79/0,61	270
15R F48 (H/V)	1,50/0,35	4/1,81	0,81/0,60	270
15R G48 (H/V)	2,20/0,50	5,2/2,6	0,81/0,58	270
15R H48 (H/V)	3,00/0,65	6,8/3	0,81/0,57	290
15R I24 (H/V)	4,00/1,00	8,4/2,58	0,92/0,78	290
15R I48 (H/V)	4,00/1,00	8,6/3,5	0,83/0,60	290
15R J24 (H/V)	5,50/1,30	11,3/3,5	0,91/0,76	310
15R J48 (H/V)	5,50/1,37	11,4/4,5	0,84/0,60	310
15R K24 (H/V)	7,50/1,87	14,8/3,6	0,91/0,89	320
15R K48 (H/V)	7,50/1,87	15,2/6,6	0,83/0,59	320
15R L24 (H/V)	9,00/2,20	13,07/4,4	0,93/0,80	330
15R L48 (H/V)	9,00/2,20	16,7/9,64	0,84/0,54	330
15R M24 (H/V)	10,00/2,00	19/4,8	0,89/0,73	330

Motor 2 speed 400 V three-phase-50 Hz 4/6 poles separate windings

PYROSTAR® Motor pwr. Rated Cos Weight  
Model (kW) current (A) (kg)

15R E46 (H/V)	1,00/0,30	3,12/1,2	0,79/0,70	270
15R F46 (H/V)	1,50/0,44	3,74/1,6	0,81/0,72	270
15R G46 (H/V)	2,20/0,65	5,5/2,5	0,80/0,73	270
15R H46 (H/V)	3,00/1,00	6,73/3,1	0,82/0,68	280
15R I46 (H/V)	4,20/1,25	9,2/5,1	0,86/0,67	310
15R J46 (H/V)	5,50/1,60	12/5,6	0,84/0,72	320
15R K46 (H/V)	7,50/2,20	14,65/5,8	0,86/0,73	340

The **250** and **200** dynamic pressures are the maximum pressures recommended for acceptable acoustic levels in comfort/smoke extraction applications.



PYROSTAR® 20A

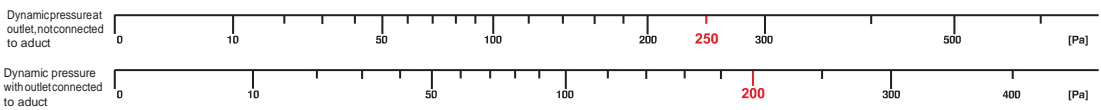
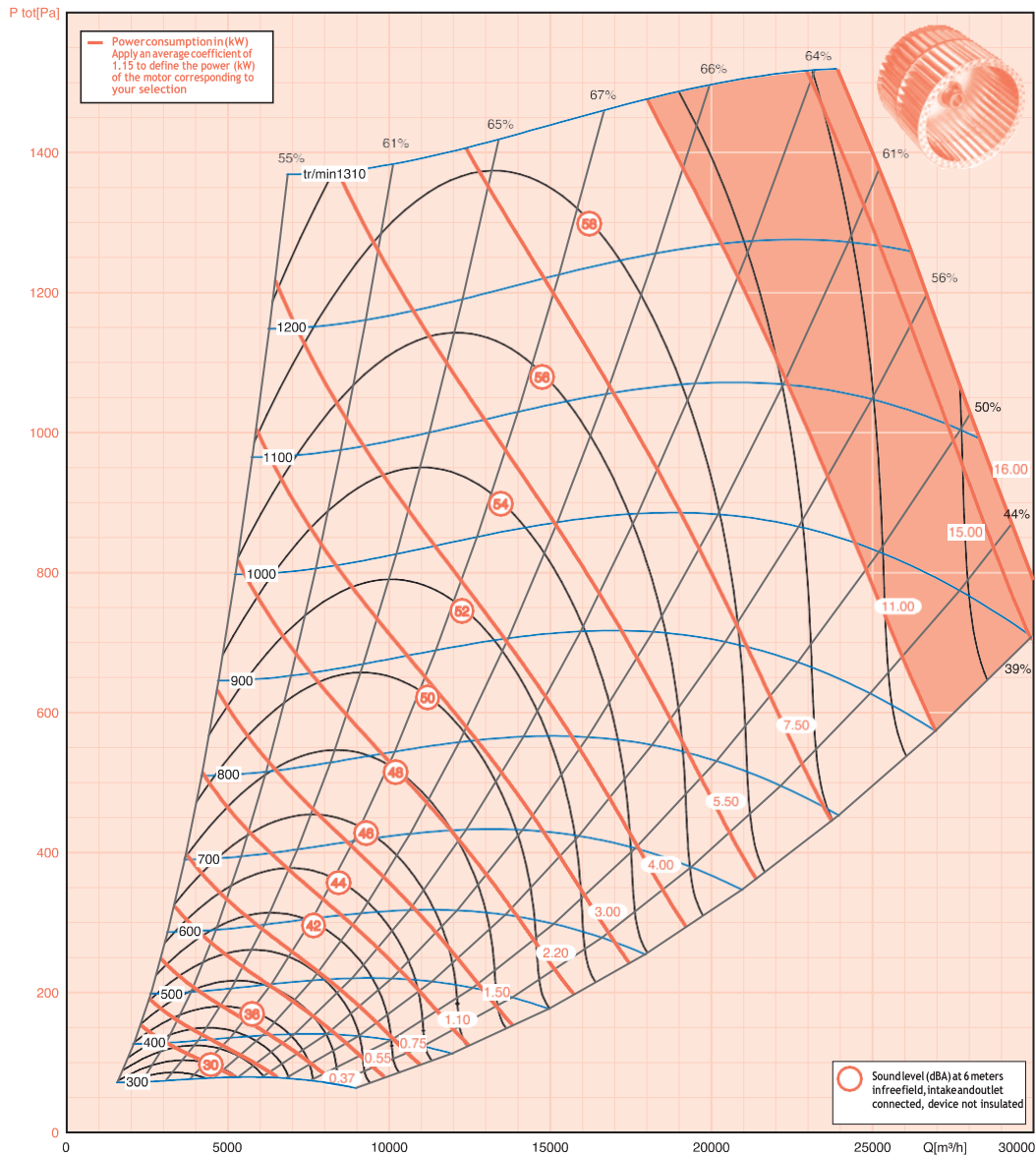

Motor 1 speed 400 V three-phase 50 Hz 2 and 4 poles				Motor 2 speed 400 V three-phase - 50 Hz 2/4 and 4/8 poles Dahlander				Motor 2 speed 400 V three-phase - 50 Hz 4/6 poles separate windings			
PYROSTAR® Model	Mo.pwr. (kW)	Rated current (A)	Cos Weight (kg)	PYROSTAR® Model	Motor pwr. (kW)	Rated current (A)	Cos Weight (kg)	PYROSTAR® Model	Motor pwr. (kW)	Rated current (A)	Cos Weight (kg)
20A E4 (H/V)	1,10	2,72	0,78 265	20A E48 (H/V)	1,10/0,26	2,9/1,51	0,79/0,61 275	20A E46 (H/V)	1,00/0,30	3,12/1,2	0,79/0,70 275
20A F4 (H/V)	1,50	3,65	0,74 275	20A F48 (H/V)	1,50/0,35	4/1,81	0,81/0,60 275	20A F46 (H/V)	1,50/0,44	3,74/1,6	0,81/0,72 275
20A G4 (H/V)	2,20	5,00	0,76 275	20A G48 (H/V)	2,20/0,050	5,2/2,6	0,81/0,58 275	20A G46 (H/V)	2,20/0,65	5,5/2,5	0,80/0,73 275
20A H4 (H/V)	3,00	6,52	0,77 275	20A H48 (H/V)	3,00/0,65	6,8/3	0,81/0,57 295	20A H46 (H/V)	3,00/1,00	6,73/3,1	0,82/0,68 285
20A I4 (H/V)	4,00	8,90	0,78 285	20A I48 (H/V)	4,00/1,00	8,6/3,5	0,83/0,60 295	20A I46 (H/V)	4,20/1,25	9,2/5,1	0,86/0,67 305
20A J4 (H/V)	5,50	11,30	0,82 295	20A J48 (H/V)	5,50/1,37	11,4/4,5	0,84/0,60 315	20A J46 (H/V)	5,50/1,60	12/5,6	0,84/0,72 325
20A K4 (H/V)	7,50	15,00	0,83 305	20A K48 (H/V)	7,50/1,87	15,2/6,6	0,83/0,59 325	20A K46 (H/V)	7,50/2,20	14,65/5,8	0,86/0,73 345
20A L4 (H/V)	9,00	19,00	0,77 325	20A L48 (H/V)	9,00/2,20	16,7/9,64	0,84/0,54 335	20A M46 (H/V)	10,50/3,30	21,4/8,6	0,85/0,77 355
20A M4 (H/V)	11,00	22,20	0,82 345	20A M48 (H/V)	11,00/2,70	22,63/8,6	0,82/0,58 335	20A N46 (H/V)	14,5/4,40	28,1/11	0,86/0,75 375
20A N4 (H/V)	15,00	28,80	0,82 365	20A N48 (H/V)	15,00/2,70	30/10,9	0,86/0,59 355	20A O46 (H/V)	20,00/6,50	39/16	0,83/0,74 395
20A O4 (H/V)	18,50	35,00	0,88 385	20A O48 (H/V)	18,50/4,50	35,95/13,28	0,82/0,59 375				

The 250 and 200 dynamic pressures are the maximum pressures recommended for acceptable acoustic levels in comfort/smoke extraction applications.





PYROSTAR® 20R

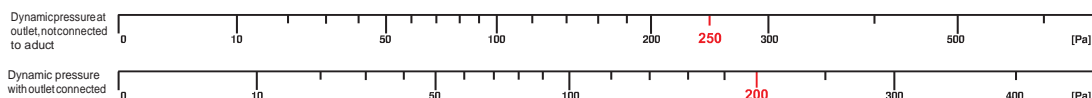
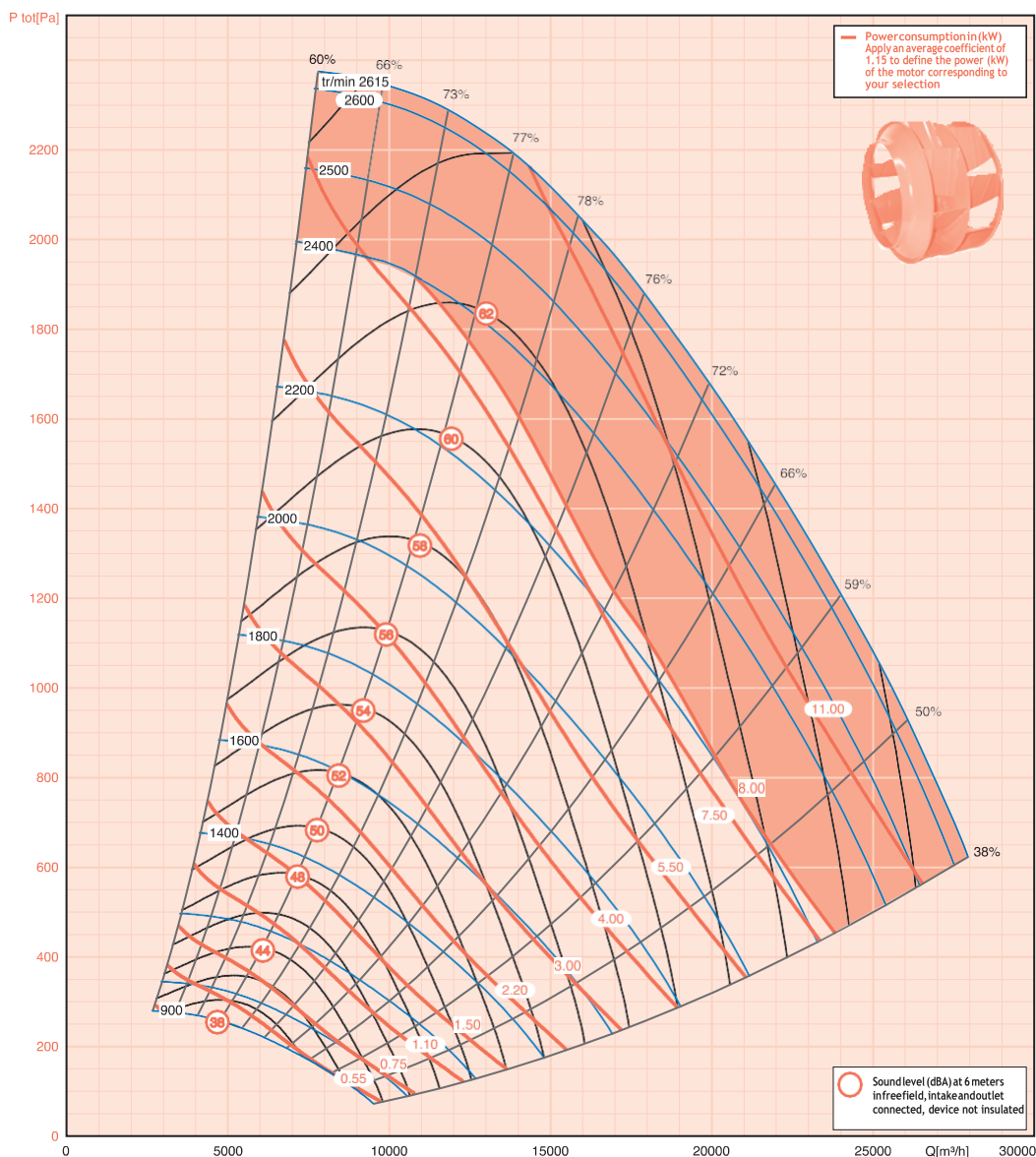

Motor 1 speed 400 V three-phase 50 Hz 2 and 4 poles				
PYROSTAR® Model	Mo. pwr. (kW)	Rated current (A)	Cos	Weight (kg)
20R E4 (H/V)	1,10	2,72	0,78	270
20R F4 (H/V)	1,50	3,65	0,74	280
20R G4 (H/V)	2,20	5,00	0,76	280
20R H4 (H/V)	3,00	6,52	0,77	280
20R I4 (H/V)	4,00	8,90	0,78	290
20R J4 (H/V)	5,50	11,30	0,82	300
20R K4 (H/V)	7,50	15,00	0,83	310
20R L4 (H/V)	9,00	19,00	0,77	330
20R M4 (H/V)	11,00	22,20	0,82	350
20R N4 (H/V)	15,00	28,80	0,82	370

Motor 2 speed 400 V three-phase -50Hz 2/4 and 4/8 poles Dahlander				
PYROSTAR® Model	Motor pwr. (kW)	Rated current (A)	Cos	Weight (kg)
20R E48 (H/V)	1,10/0,26	2,9/1,51	0,79/0,61	280
20R F48 (H/V)	1,50/0,35	4/1,81	0,81/0,60	280
20R G48 (H/V)	2,20/0,50	5,2/2,6	0,81/0,58	280
20R H48 (H/V)	3,00/0,65	6,8/3	0,81/0,57	300
20R I48 (H/V)	4,00/1,00	8,6/3,5	0,83/0,60	300
20R J48 (H/V)	5,50/1,37	11,4/4,5	0,84/0,60	320
20R K48 (H/V)	7,50/1,87	15,2/6,6	0,83/0,59	330
20R L48 (H/V)	9,00/2,20	16,7/9,64	0,84/0,54	340
20R M48 (H/V)	11,00/2,70	22,63/8,6	0,82/0,58	340
20R N48 (H/V)	15,00/2,70	30/10,9	0,86/0,59	360

Motor 2 speed 400 V three-phase -50Hz 4/6 poles separate windings				
PYROSTAR® Model	Motor pwr. (kW)	Rated current (A)	Cos	Weight (kg)
20R F46 (H/V)	1,50/0,44	3,74/1,6	0,81/0,72	280
20R G46 (H/V)	2,20/0,65	5,5/2,5	0,80/0,73	280
20R H46 (H/V)	3,00/1,00	6,73/3,1	0,82/0,68	290
20R I46 (H/V)	4,20/1,25	9,2/5,1	0,86/0,67	310
20R J46 (H/V)	5,50/1,60	12/5,6	0,84/0,72	330
20R K46 (H/V)	7,50/2,20	14,65/5,8	0,86/0,73	350
20R M46 (H/V)	10,50/3,30	21,4/8,6	0,85/0,77	360
20R N46 (H/V)	14,5/4,40	28,1/11	0,86/0,75	380

The 250 and 200 dynamic pressures are the maximum pressures recommended for acceptable acoustic levels in comfort/smoke extraction applications.

3

SMOKE EXTRACTION

SELECTION  
CURVES

PYROSTAR®

PYROSTAR® 25A

**Power consumption in (kW)**  
Apply an average coefficient of 1.15 to define the power (kW) of the motor corresponding to your selection

**Sound level (dBA) at 6 meters**  
In free field, intake and outlet connected, device not insulated

Dynamic pressure at outlet, not connected to aduct: 0, 10, 50, 100, 200, 250, 300, 500 [Pa]

Dynamic pressure with outlet connected to aduct: 0, 10, 50, 100, 200 [Pa]

Smoke extraction only

Motor 1 speed 400 V three-phase 50 Hz 2 and 4 poles				Motor 2 speed 400 V three-phase -50 Hz 2/4 and 4/8 poles Dahlander				Motor 2 speed 400 V three-phase -50 Hz 4/6 poles separate windings						
PYROSTAR® Model	Mo.pwr. (kW)	Rated current (A)	Weight (kg)	PYROSTAR® Model	Motor pwr. (kW)	Rated current (A)	Cos	Weight (kg)	PYROSTAR® Model	Motor pwr. (kW)	Rated current (A)	Cos	Weight (kg)	
25A F4 (H/V)	1,50	3,65	0,74	355	25A F48 (H/V)	1,50/0,35	4/1,81	0,81/0,60	355	25A F46 (H/V)	1,50/0,44	3,74/1,6	0,81/0,72	355
25A G4 (H/V)	2,20	5,00	0,76	355	25A G48 (H/V)	2,20/0,050	5,2/2,6	0,81/0,58	355	25A G46 (H/V)	2,20/0,65	5,5/2,5	0,80/0,73	355
25A H4 (H/V)	3,00	6,52	0,77	355	25A H48 (H/V)	3,00/0,65	6,8/3	0,81/0,57	375	25A H46 (H/V)	3,00/1,00	6,73/3,1	0,82/0,68	365
25A I4 (H/V)	4,00	8,90	0,78	365	25A I48 (H/V)	4,00/1,00	8,6/3,5	0,83/0,60	375	25A I46 (H/V)	4,20/1,25	9,2/5,1	0,86/0,67	385
25A J4 (H/V)	5,50	11,30	0,82	375	25A J48 (H/V)	5,50/1,37	11,4/4,5	0,84/0,60	395	25A J46 (H/V)	5,50/1,60	12/5,6	0,84/0,72	405
25A K4 (H/V)	7,50	15,00	0,83	385	25A K48 (H/V)	7,50/1,87	15,2/6,6	0,83/0,59	405	25A K46 (H/V)	7,50/2,20	14,65/5,8	0,86/0,73	425
25A L4 (H/V)	9,00	19,00	0,77	405	25A L48 (H/V)	9,00/2,20	16,7/9,64	0,84/0,54	415	25A M46 (H/V)	10,50/3,30	21,4/8,6	0,85/0,77	435
25A M4 (H/V)	11,00	22,20	0,82	425	25A M48 (H/V)	11,00/2,70	22,63/8,6	0,82/0,58	415	25A N46 (H/V)	14,5/4,40	28,1/11	0,86/0,75	455
25A N4 (H/V)	15,00	28,80	0,82	445	25A N48 (H/V)	15,00/2,70	30/10,9	0,86/0,59	425	25A O46 (H/V)	20,00/6,50	39/16	0,83/0,74	475
25A O4 (H/V)	18,50	35,00	0,88	465	25A O48 (H/V)	18,50/4,50	35,95/13,28	0,82/0,59	445					

The **250** and **200** dynamic pressures are the maximum pressures recommended for acceptable acoustic levels in comfort/smoke extraction applications.

P284

CALADAIR | 61 rue de Saint Véran | 71000 MÂCON LOCHÉ | Tél. 33 (0)3 85 36 82 00 – Fax 33 (0)3 85 36 82 01 | www.caladair.com



## PYROSTAR® 25R

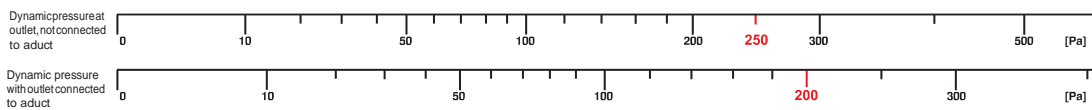
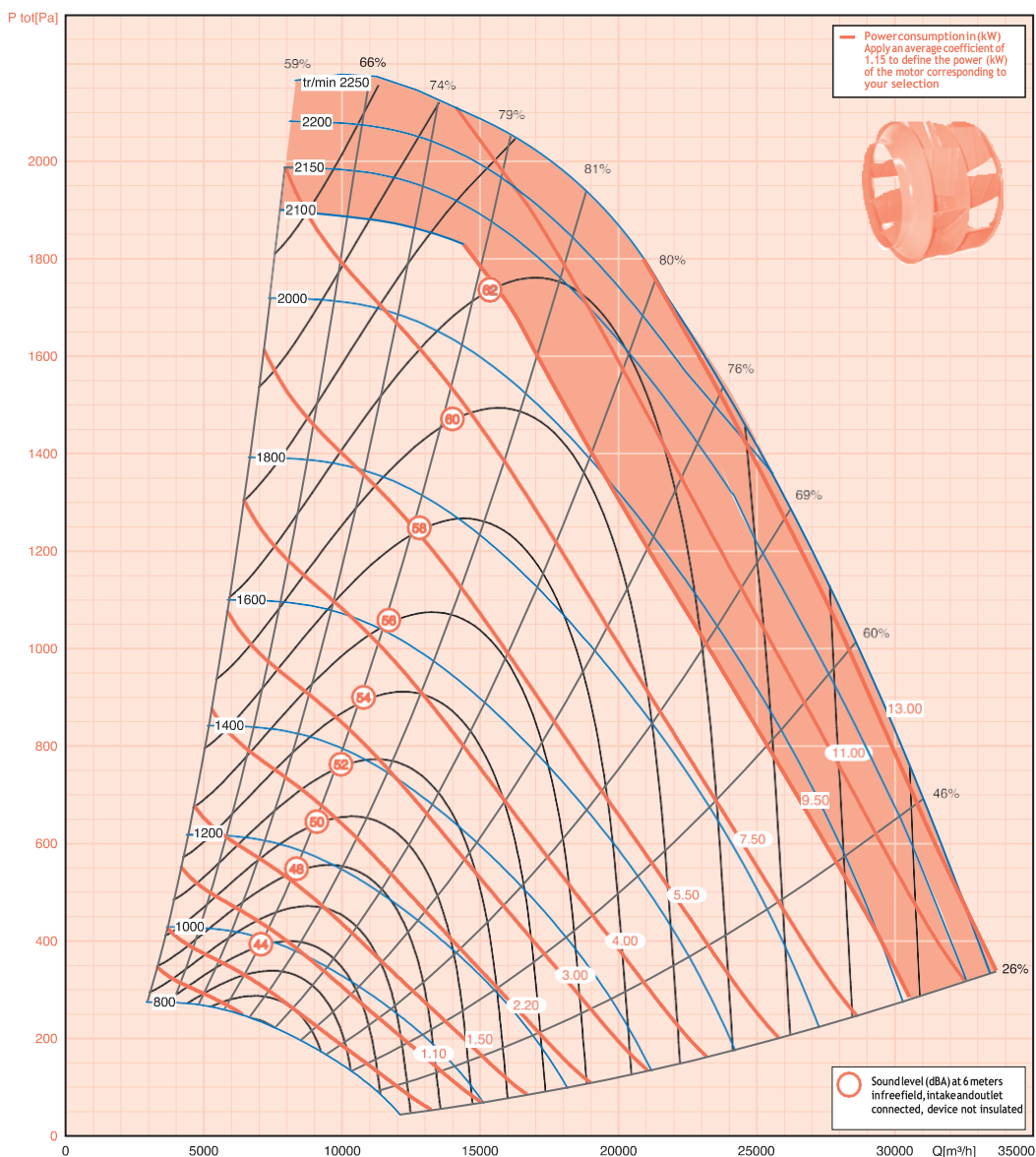

Motor 1 speed 400 V three-phase 50 Hz 2 and 4 poles				
PYROSTAR® Model	Mo.pwr. (kW)	Rated current (A)	Cos	Weight (kg)
25R F4 (H/V)	1,50	3,65	0,74	365
25R G4 (H/V)	2,20	5,00	0,76	365
25R H4 (H/V)	3,00	6,52	0,77	365
25R I4 (H/V)	4,00	8,90	0,78	375
25R J4 (H/V)	5,50	11,30	0,82	385
25R K4 (H/V)	7,50	15,00	0,83	395
25R L4 (H/V)	9,00	19,00	0,77	415
25R M4 (H/V)	11,00	22,2	0,82	435
25R N4 (H/V)	15,00	28,80	0,82	455

Motor 2 speed 400 V three-phase - 50 Hz 2/4 and 4/8 poles Dahlander				
PYROSTAR® Model	Motor pwr. (kW)	Rated current (A)	Cos	Weight (kg)
25R F48 (H/V)	1,50/0,35	4/1,81	0,81/0,60	365
25R G48 (H/V)	2,20/0,50	5,2/2,6	0,81/0,58	365
25R H48 (H/V)	3,00/0,65	6,8/3	0,81/0,57	385
25R I48 (H/V)	4,00/1,00	8,6/3,5	0,83/0,60	385
25R J48 (H/V)	5,50/1,37	11,4/4,5	0,84/0,60	405
25R K48 (H/V)	7,50/1,87	15,2/6,6	0,83/0,59	415
25R L48 (H/V)	9,00/2,20	16,7/9,64	0,84/0,54	425
25R M48 (H/V)	11,00/2,70	22,63/8,6	0,82/0,58	425
25R N48 (H/V)	15,00/2,70	30/10,9	0,86/0,59	435

Motor 2 speed 400 V three-phase - 50 Hz 4/6 poles separate windings				
PYROSTAR® Model	Motor pwr. (kW)	Rated current (A)	Cos	Weight (kg)
25R F46 (H/V)	1,50/0,44	3,74/1,6	0,81/0,72	365
25R G46 (H/V)	2,20/0,65	5,5/2,5	0,80/0,73	365
25R H46 (H/V)	3,00/1,00	6,73/3,1	0,82/0,68	375
25R I46 (H/V)	4,20/1,25	9,2/5,1	0,86/0,67	395
25R J46 (H/V)	5,50/1,60	12/5,6	0,84/0,72	415
25R K46 (H/V)	7,50/2,20	14,65/5,8	0,86/0,73	435
25R M46 (H/V)	10,50/3,30	21,4/8,6	0,85/0,77	445
25R N46 (H/V)	14,5/4,40	28,1/11	0,86/0,75	465

The **250** and **200** dynamic pressures are the maximum pressures recommended for acceptable acoustic levels in comfort/smoke extraction applications.

3

SMOKE EXTRACTION

SELECTION  
CURVES

PYROSTAR®

PYROSTAR® 30A

**P to [Pa]**

**Q [m³/h]**

Power consumption in (kW)  
Apply an average coefficient of 1,15 to define the power (kW) of the motor corresponding to your selection

Sound level (dBA) at 6 meters in free field, intake and outlet connected, device not insulated

Smoke extraction only

Dynamic pressure at outlet, not connected to aduct

Dynamic pressure with outlet connected to aduct

Motor 1 speed 400 V three-phase 50 Hz 2 and 4 poles				
PYROSTAR® Model	Mo.pwr. (kW)	Rated current (A)	Cos	Weight (kg)
30A F4 (H/V)	1,50	3,65	0,74	375
30A G4 (H/V)	2,20	5,00	0,76	375
30A H4 (H/V)	3,00	6,52	0,77	385
30A I4 (H/V)	4,00	8,90	0,78	385
30A J4 (H/V)	5,50	11,30	0,82	405
30A K4 (H/V)	7,50	15,00	0,83	415
30A L4 (H/V)	9,00	19,00	0,77	425
30A M4 (H/V)	11,00	22,20	0,82	445
30A N4 (H/V)	15,00	28,80	0,82	465
30A O4 (H/V)	18,50	35,00	0,88	485
30A P4 (H/V)	22,00	39,50	0,87	505

Motor 2 speed 400 V three-phase -50Hz 2/4 and 4/8 poles Dahlander				
PYROSTAR® Model	Motor pwr. (kW)	Rated current (A)	Cos	Weight (kg)
30A F48 (H/V)	1,50/0,35	4/1,81	0,81/0,60	385
30A G48 (H/V)	2,20/0,50	5,2/2,6	0,81/0,58	385
30A H48 (H/V)	3,00/0,65	6,8/3	0,81/0,57	395
30A I48 (H/V)	4,00/1,00	8,6/3,5	0,83/0,60	395
30A J48 (H/V)	5,50/1,37	11,4/4,5	0,84/0,60	415
30A K48 (H/V)	7,50/1,87	15,2/6,6	0,83/0,59	425
30A L48 (H/V)	9,00/2,20	16,7/9,64	0,84/0,54	435
30A M48 (H/V)	11,00/2,70	22,63/8,6	0,82/0,58	435
30A N48 (H/V)	15,00/2,70	30/10,9	0,86/0,59	445
30A O48 (H/V)	18,50/4,50	35,95/13,28	0,82/0,59	475
30A P48 (H/V)	22,00/4,40	43/17,4	0,83/0,57	495

Motor 2 speed 400 V three-phase -50Hz 4/6 poles separate windings				
PYROSTAR® Model	Motor pwr. (kW)	Rated current (A)	Cos	Weight (kg)
30A F46 (H/V)	1,50/0,44	3,74/1,6	0,81/0,72	375
30A G46 (H/V)	2,20/0,65	5,5/2,5	0,80/0,73	385
30A H46 (H/V)	3,00/1,00	6,73/3,1	0,82/0,68	385
30A I46 (H/V)	4,20/1,25	9,2/5,1	0,86/0,67	415
30A J46 (H/V)	5,50/1,60	12/5,6	0,84/0,72	425
30A K46 (H/V)	7,50/2,20	14,65/5,8	0,86/0,73	445
30A M46 (H/V)	10,50/3,30	21,4/8,6	0,85/0,77	455
30A N46 (H/V)	14,5/4,40	28,1/11	0,86/0,75	475
30A O46 (H/V)	20,00/6,50	39/16	0,83/0,74	495
30A P46 (H/V)	23,00/7,20	43/15	0,88/0,87	515

The **250** and **200** dynamic pressures are the maximum pressures recommended for acceptable acoustic levels in comfort/smoke extraction applications.

P286



## PYROSTAR® 30R

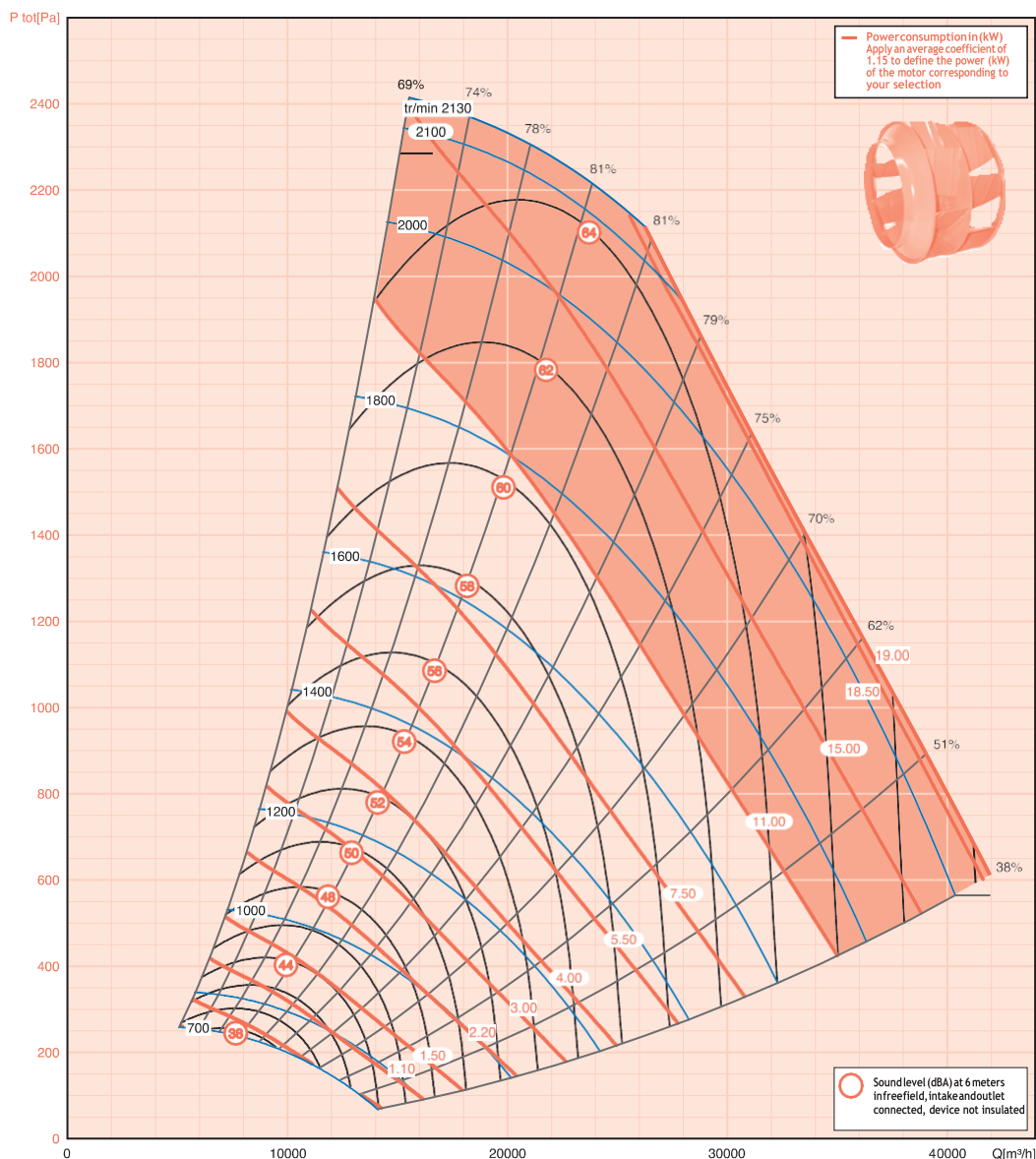

Smoke extraction only

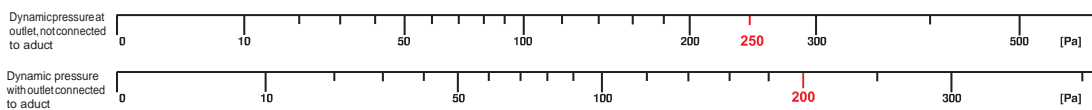

Motor 1 speed 400 V three-phase 50 Hz 2 and 4 poles

PYROSTAR® Model	Mo.pwr. (kW)	Rated current (A)	Cos	Weight (kg)
30R F4 (H/V)	1,50	3,65	0,74	385
30R G4 (H/V)	2,20	5,00	0,76	385
30R H4 (H/V)	3,00	6,52	0,77	395
30R I4 (H/V)	4,00	8,90	0,78	395
30R J4 (H/V)	5,50	11,30	0,82	415
30R K4 (H/V)	7,50	15,00	0,83	425
30R L4 (H/V)	9,00	19,00	0,77	435
30R M4 (H/V)	11,00	22,20	0,82	455
30R N4 (H/V)	15,00	28,80	0,82	475
30R O4 (H/V)	18,50	35,00	0,88	495
30R P4 (H/V)	22,00	39,5	0,87	515

Motor 2 speed 400 V three-phase-50 Hz 2/4 and 4/8 poles Dahlander

PYROSTAR® Model	Motor pwr. (kW)	Rated current (A)	Cos	Weight (kg)
30R F48 (H/V)	1,50/0,35	4/1,81	0,81/0,60	395
30R G48 (H/V)	2,20/0,50	5,2/2,6	0,81/0,58	395
30R H48 (H/V)	3,00/0,65	6,8/3	0,81/0,57	405
30R I48 (H/V)	4,00/1,00	8,6/3,5	0,83/0,60	405
30R J48 (H/V)	5,50/1,37	11,4/4,5	0,84/0,60	425
30R K48 (H/V)	7,50/1,87	15,2/6,6	0,83/0,59	435
30R L48 (H/V)	9,00/2,20	16,7/9,64	0,84/0,54	445
30R M48 (H/V)	11,00/2,70	22,63/8,6	0,82/0,58	445
30R N48 (H/V)	15,00/2,70	30/10,9	0,86/0,59	455
30R O48 (H/V)	18,50/4,50	35,95/13,28	0,82/0,59	485
30R P48 (H/V)	22,00/4,40	43/17,4	0,83/0,57	505

Motor 2 speed 400 V three-phase-50 Hz 4/6 poles separate windings

PYROSTAR® Model	Motor pwr. (kW)	Rated current (A)	Cos	Weight (kg)
30R F46 (H/V)	1,50/0,44	3,74/1,6	0,81/0,72	385
30R G46 (H/V)	2,20/0,65	5,5/2,5	0,80/0,73	395
30R H46 (H/V)	3,00/1,00	6,73/3,1	0,82/0,68	395
30R I46 (H/V)	4,20/1,25	9,2/5,1	0,86/0,67	425
30R J46 (H/V)	5,50/1,60	12/5,6	0,84/0,72	435
30R K46 (H/V)	7,50/2,20	14,65/5,8	0,86/0,73	455
30R M46 (H/V)	10,50/3,30	21,4/8,6	0,85/0,77	465
30R N46 (H/V)	14,5/4,40	28,1/11	0,86/0,75	485
30R O46 (H/V)	20,00/6,50	39/16	0,83/0,74	505
30R P46 (H/V)	23,00/7,20	43/15	0,88/0,87	525

The **250** and **200** dynamic pressures are the maximum pressures recommended for acceptable acoustic levels in comfort/smoke extraction applications.

3

SMOKE EXTRACTION

SELECTION  
CURVES

PYROSTAR®

PYROSTAR® 40A

**Power consumption in (kW)**  
Apply an average coefficient of 1,15 to define the power (kW) of the motor corresponding to your selection

**Sound level (dBA) at 6 meters**  
In free field, intake and outlet connected, device not insulated

**Smoke extraction only**

Dynamic pressure at outlet, not connected to duct [Pa]

Dynamic pressure with outlet connected [Pa]

Motor 1 speed 400 V three-phase 50 Hz 2 and 4 poles

PYROSTAR® Model	Mo.pwr. (kW)	Rated current (A)	Cos	Weight (kg)
40A G4 (H/V)	2,20	5,00	0,76	490
40A H4 (H/V)	3,00	6,52	0,77	490
40A I4 (H/V)	4,00	8,90	0,78	500
40A J4 (H/V)	5,50	11,30	0,82	510
40A K4 (H/V)	7,50	15,00	0,83	520
40A L4 (H/V)	9,00	19,00	0,77	530
40A M4 (H/V)	11,00	22,20	0,82	560
40A N4 (H/V)	15,00	28,80	0,82	580
40A O4 (H/V)	18,50	35,00	0,88	590
40A P4 (H/V)	22,00	39,50	0,87	605
40A Q4 (H/V)	30,00	55,70	0,86	615

Motor 2 speed 400 V three-phase - 50 Hz 2/4 and 4/8 poles Dahlander

PYROSTAR® Model	Motor pwr. (kW)	Rated current (A)	Cos	Weight (kg)
40A G48 (H/V)	2,20/0,050	5,2/2,6	0,81/0,58	490
40A H48 (H/V)	3,00/0,65	6,8/3	0,81/0,57	510
40A I48 (H/V)	4,00/1,00	8,6/3,5	0,83/0,60	510
40A J48 (H/V)	5,50/1,37	11,4/4,5	0,84/0,60	530
40A K48 (H/V)	7,50/1,87	15,2/6,6	0,83/0,59	530
40A L48 (H/V)	9,00/2,20	16,7/9,64	0,84/0,54	540
40A M48 (H/V)	11,00/2,70	22,63/8,6	0,82/0,58	550
40A N48 (H/V)	15,00/2,70	30/10,9	0,86/0,59	560
40A O48 (H/V)	18,50/4,50	35,95/13,28	0,82/0,59	580
40A P48 (H/V)	22,00/4,40	43/17,4	0,83/0,57	595
40A Q48 (H/V)	30,00/7,50	61/21,33	0,85/0,64	605

Motor 2 speed 400 V three-phase - 50 Hz 4/6 poles separate windings

PYROSTAR® Model	Motor pwr. (kW)	Rated current (A)	Cos	Weight (kg)
40A G46 (H/V)	2,20/0,65	5,5/2,5	0,80/0,73	490
40A H46 (H/V)	3,00/1,00	6,73/3,1	0,82/0,68	500
40A I46 (H/V)	4,20/1,25	9,2/5,1	0,86/0,67	520
40A J46 (H/V)	5,50/1,60	12/5,6	0,84/0,72	540
40A K46 (H/V)	7,50/2,20	14,65/5,8	0,86/0,73	560
40A M46 (H/V)	10,50/3,30	21,4/8,6	0,85/0,77	570
40A N46 (H/V)	14,5/4,40	28,1/11	0,86/0,75	580
40A O46 (H/V)	20,00/6,50	39/16	0,83/0,74	600
40A P46 (H/V)	23,00/7,20	43/15	0,88/0,87	615
40A Q46 (H/V)	30,00/9,00	54/18,2	0,90/0,84	625

The 250 and 200 dynamic pressures are the maximum pressures recommended for acceptable acoustic levels in comfort/smoke extraction applications.

P288



PYROSTAR® 40R

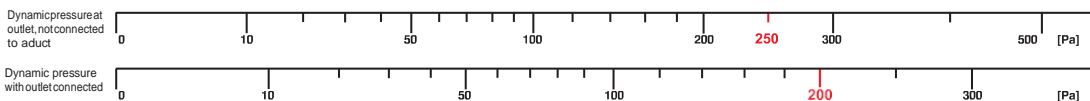
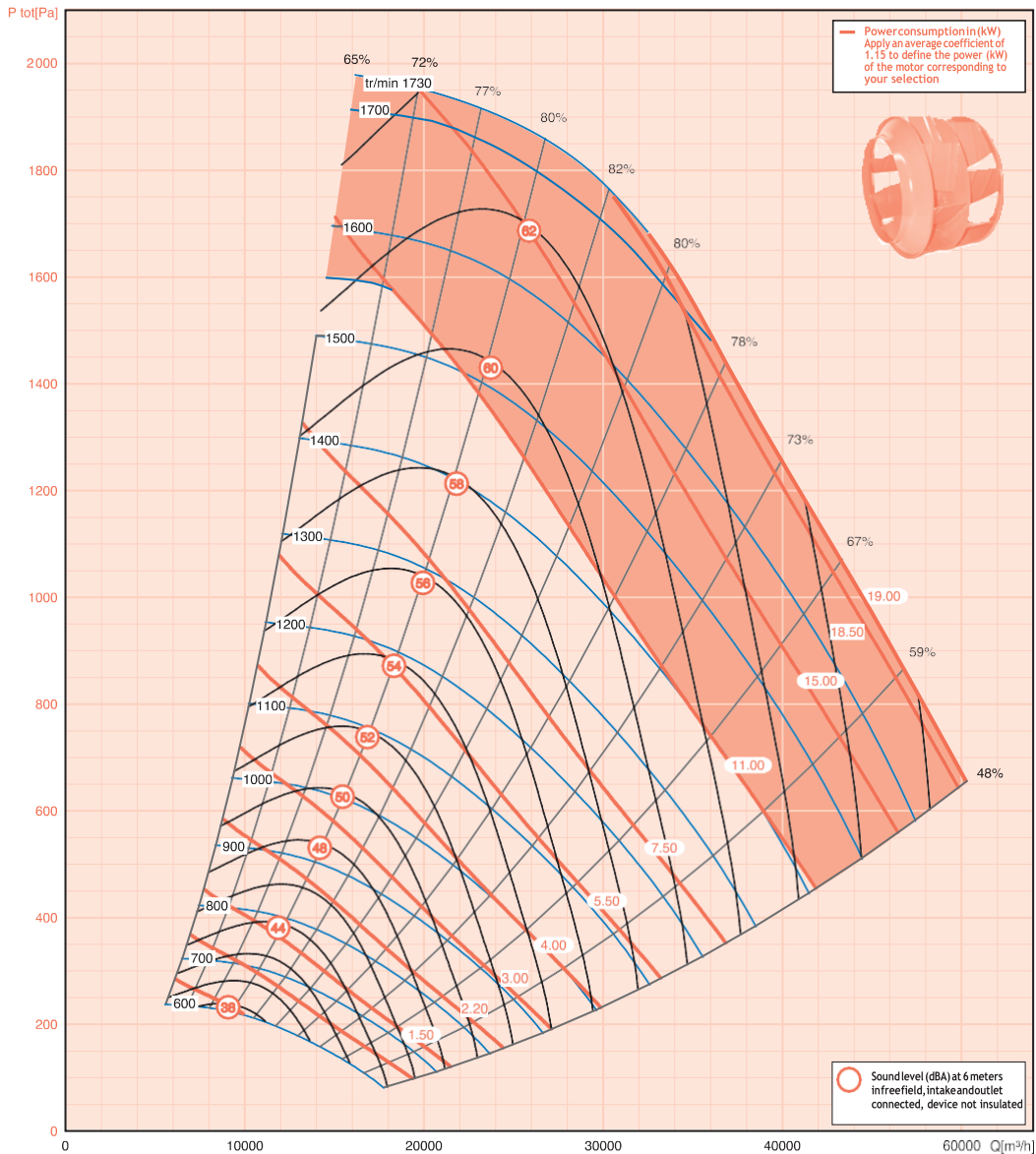

Motor 1 speed 400 V three-phase 50 Hz 2 and 4 poles			
PYROSTAR® Model	Mo.pwr. (kW)	Rated current (A)	Weight (kg)
40R G4 (H/V)	2,20	5,00	0,76 500
40R H4 (H/V)	3,00	6,52	0,77 500
40R I4 (H/V)	4,00	8,90	0,78 510
40R J4 (H/V)	5,50	11,30	0,82 520
40R K4 (H/V)	7,50	15,00	0,83 530
40R L4 (H/V)	9,00	19,00	0,77 540
40R M4 (H/V)	11,00	22,20	0,82 570
40R N4 (H/V)	15,00	28,80	0,82 590
40R O4 (H/V)	18,50	35,00	0,88 600
40R P4 (H/V)	22,00	39,50	0,87 615

Motor 2 speed 400 V three-phase - 50Hz 2/4 and 4/8 poles Dahlander			
PYROSTAR® Model	Motor pwr. (kW)	Rated current (A)	Cos Weight (kg)
40R G48 (H/V)	2,20/0,50	5,2/2,6	0,81/0,58 500
40R H48 (H/V)	3,00/0,65	6,8/3	0,81/0,57 520
40R I48 (H/V)	4,00/1,00	8,6/3,5	0,83/0,60 520
40R J48 (H/V)	5,50/1,37	11,4/4,5	0,84/0,60 540
40R K48 (H/V)	7,50/1,87	15,2/6,6	0,83/0,59 540
40R L48 (H/V)	9,00/2,20	16,7/9,64	0,84/0,54 550
40R M48 (H/V)	11,00/2,70	22,63/8,6	0,82/0,58 560
40R N48 (H/V)	15,00/2,70	30/10,9	0,86/0,59 570
40R O48 (H/V)	18,50/4,50	35,95/13,28	0,82/0,59 590
40R P48 (H/V)	22,00/4,40	43/17,4	0,83/0,57 605

Motor 2 speed 400 V three-phase - 50Hz 4/6 poles separate windings			
PYROSTAR® Model	Motor pwr. (kW)	Rated current (A)	Cos Weight (kg)
40R G46 (H/V)	2,20/0,65	5,5/2,5	0,80/0,73 500
40R H46 (H/V)	3,00/1,00	6,73/3,1	0,82/0,68 510
40R I46 (H/V)	4,20/1,25	9,2/5,1	0,86/0,67 530
40R J46 (H/V)	5,50/1,60	12/5,6	0,84/0,72 550
40R K46 (H/V)	7,50/2,20	14,65/5,8	0,86/0,73 570
40R M46 (H/V)	10,50/3,30	21,4/8,6	0,85/0,77 580
40R N46 (H/V)	14,5/4,40	28,1/11	0,86/0,75 590
40R O46 (H/V)	20,00/6,50	39/16	0,83/0,74 610
40R P46 (H/V)	23,00/7,20	43/15	0,88/0,87 625

The 250 and 200 dynamic pressures are the maximum pressures recommended for acceptable acoustic levels in comfort/smoke extraction applications.



PYROSTAR® 50A

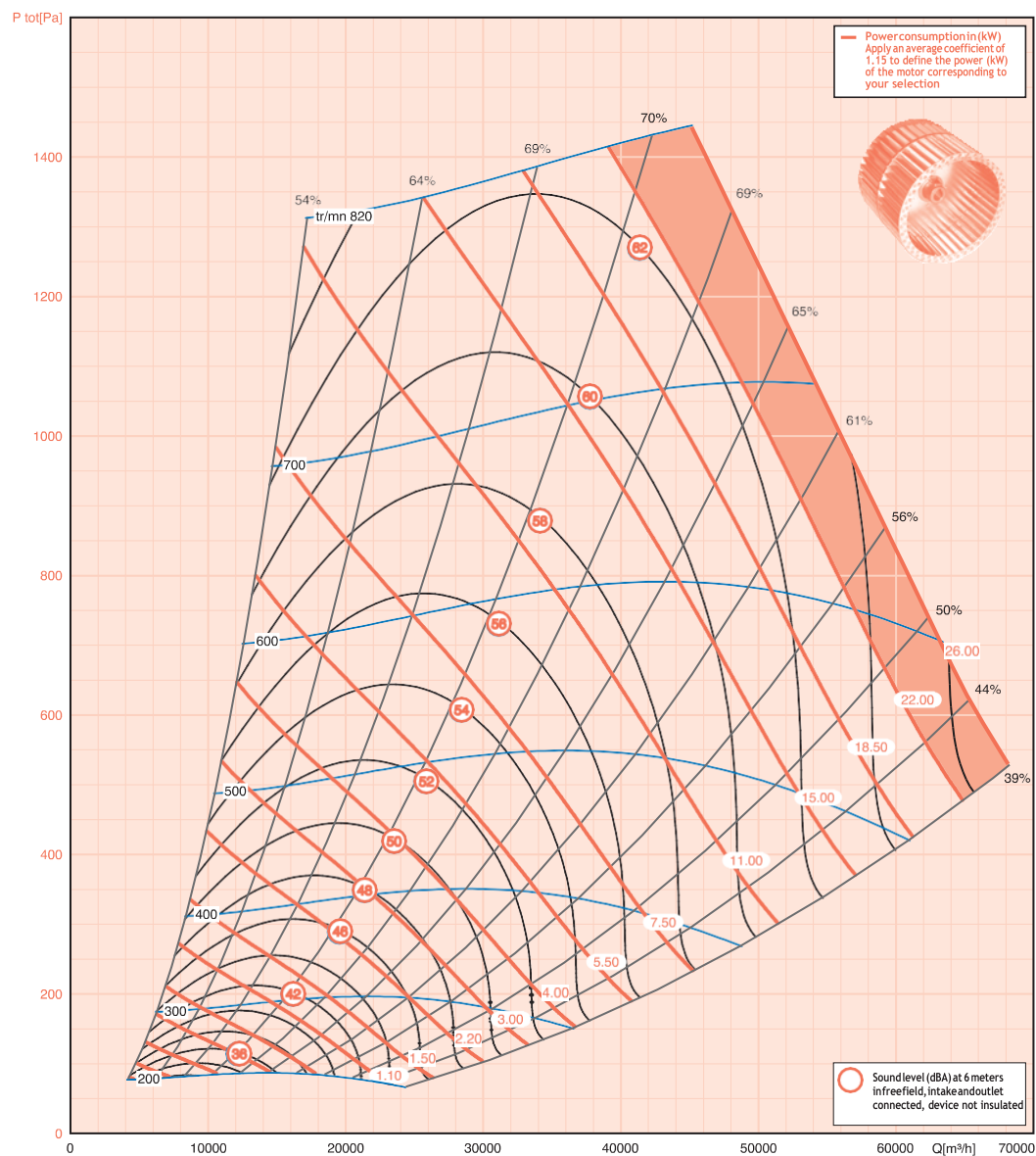

Smoke extraction only

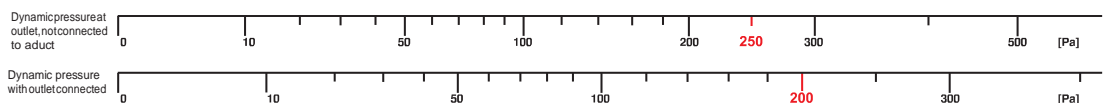

Motor 1 speed 400 V three-phase 50 Hz 2 and 4 poles			
PYROSTAR® Model	Mo.pwr. (kW)	Rated current (A)	Cos Weight (kg)
50A G4 (H/V)	2,20	5,00	0,76 530
50A H4 (H/V)	3,00	6,52	0,77 530
50A I4 (H/V)	4,00	8,90	0,78 540
50A J4 (H/V)	5,50	11,30	0,82 550
50A K4 (H/V)	7,50	15,00	0,83 560
50A L4 (H/V)	9,00	19,00	0,77 570
50A M4 (H/V)	11,00	22,20	0,82 600
50A N4 (H/V)	15,00	28,80	0,82 610
50A O4 (H/V)	18,50	35,00	0,88 630
50A P4 (H/V)	22,00	39,50	0,87 645
50A Q4 (H/V)	30,00	55,70	0,86 655

Motor 2 speed 400 V three-phase - 50 Hz 2/4 and 4/8 poles Dahlander			
PYROSTAR® Model	Motor pwr. (kW)	Rated current (A)	Cos Weight (kg)
50A G48 (H/V)	2,20/0,050	5,2/2,6	0,81/0,58 530
50A H48 (H/V)	3,00/0,65	6,8/3	0,81/0,57 540
50A I48 (H/V)	4,00/1,00	8,6/3,5	0,83/0,60 550
50A J48 (H/V)	5,50/1,37	11,4/4,5	0,84/0,60 570
50A K48 (H/V)	7,50/1,87	15,2/6,6	0,83/0,59 570
50A L48 (H/V)	9,00/2,20	16,7/9,64	0,84/0,54 580
50A M48 (H/V)	11,00/2,70	22,63/8,6	0,82/0,58 590
50A N48 (H/V)	15,00/2,70	30/10,9	0,86/0,59 600
50A O48 (H/V)	18,50/4,50	35,95/13,28	0,82/0,59 620
50A P48 (H/V)	22,00/4,40	43/17,4	0,83/0,57 635
50A Q48 (H/V)	30,00/7,50	61/21,33	0,85/0,64 645

Motor 2 speed 400 V three-phase - 50 Hz 4/6 poles separate windings			
PYROSTAR® Model	Motor pwr. (kW)	Rated current (A)	Cos Weight (kg)
50A G46 (H/V)	2,20/0,65	5,5/2,5	0,80/0,73 530
50A H46 (H/V)	3,00/1,00	6,73/3,1	0,82/0,68 540
50A I46 (H/V)	4,20/1,25	9,2/5,1	0,86/0,67 560
50A J46 (H/V)	5,50/1,60	12/5,6	0,84/0,72 580
50A K46 (H/V)	7,50/2,20	14,65/5,8	0,86/0,73 600
50A M46 (H/V)	10,50/3,30	21,4/8,6	0,85/0,77 610
50A N46 (H/V)	14,5/4,40	28,1/11	0,86/0,75 620
50A O46 (H/V)	20,00/6,50	39/16	0,83/0,74 640
50A P46 (H/V)	23,00/7,20	43/15	0,88/0,87 655
50A Q46 (H/V)	30,00/9,00	54/18,2	0,90/0,84 665

The 250 and 200 dynamic pressures are the maximum pressures recommended for acceptable acoustic levels in comfort/smoke extraction applications.





PYROSTAR® 50R

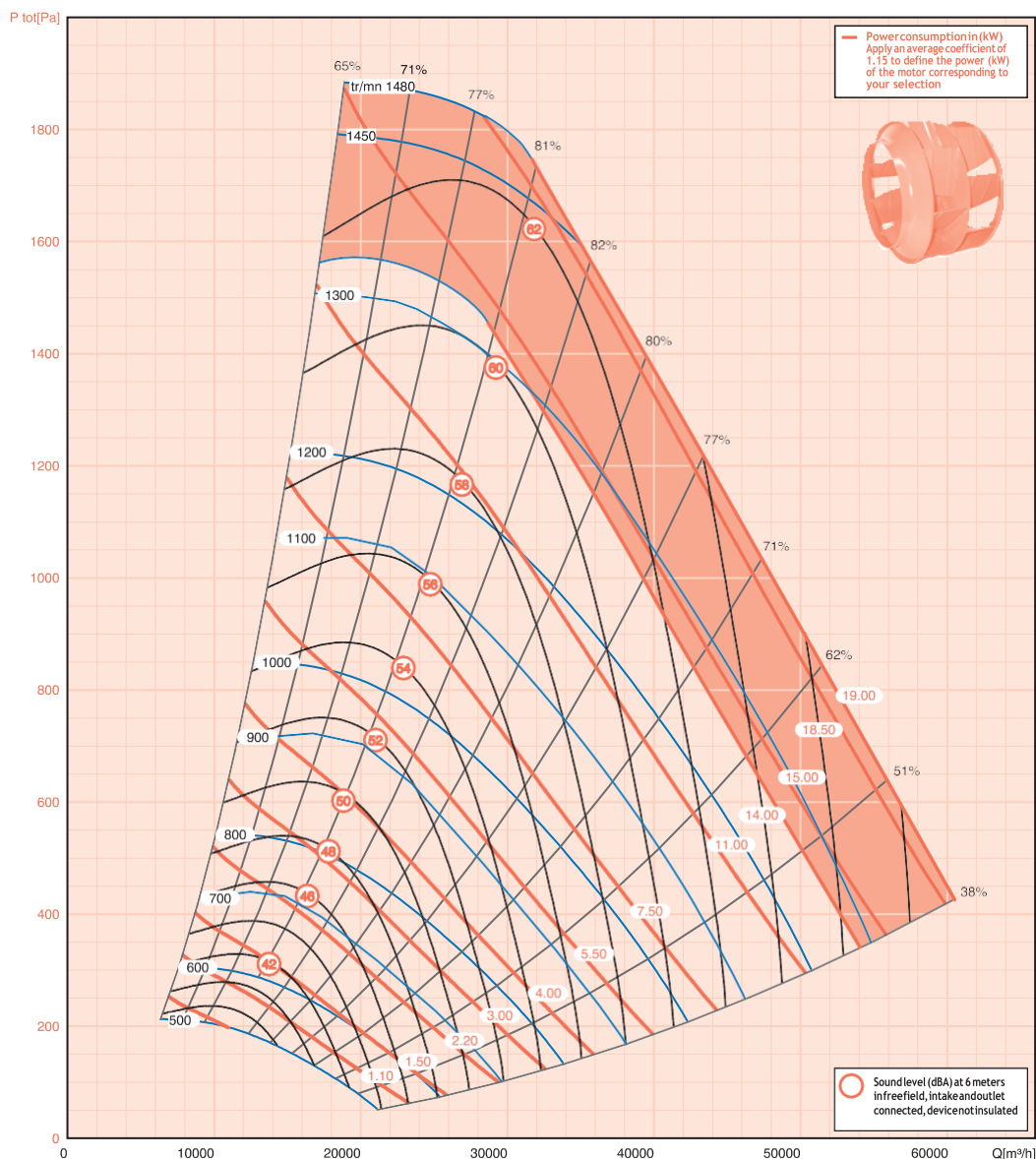

Smoke extraction only

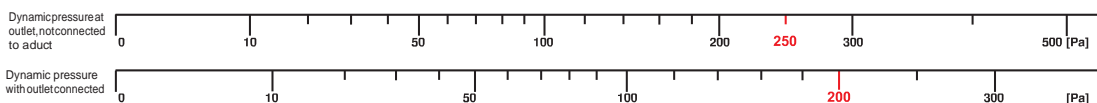

Motor 1 speed 400 V three-phase 50 Hz 2 and 4 poles			
PYROSTAR® Model	Mo. pwr. (kW)	Rated current (A)	Weight (kg)
50R G4 (H/V)	2,20	5,00	0,76 540
50R H4 (H/V)	3,00	6,52	0,77 540
50R I4 (H/V)	4,00	8,90	0,78 550
50R J4 (H/V)	5,50	11,30	0,82 560
50R K4 (H/V)	7,50	15,00	0,83 570
50R L4 (H/V)	9,00	19,00	0,77 580
50R M4 (H/V)	11,00	22,20	0,82 610
50R N4 (H/V)	15,00	28,80	0,82 620
50R O4 (H/V)	18,50	35,00	0,88 640
50R P4 (H/V)	22,00	39,50	0,87 655

Motor 2 speed 400 V three-phase - 50 Hz 2/4 and 4/8 poles Dahlander			
PYROSTAR® Model	Motor pwr. (kW)	Rated current (A)	Cos Weight (kg)
50R G48 (H/V)	2,20/0,050	5,2/2,6	0,81/0,58 540
50R H48 (H/V)	3,00/0,65	6,8/3	0,81/0,57 550
50R I48 (H/V)	4,00/1,00	8,6/3,5	0,83/0,60 560
50R J48 (H/V)	5,50/1,37	11,4/4,5	0,84/0,60 580
50R K48 (H/V)	7,50/1,87	15,2/6,6	0,83/0,59 580
50R L48 (H/V)	9,00/2,20	16,7/9,64	0,84/0,54 590
50R M48 (H/V)	11,00/2,70	22,63/8,6	0,82/0,58 600
50R N48 (H/V)	15,00/2,70	30/10,9	0,86/0,59 610
50R O48 (H/V)	18,50/4,50	35,95/13,28	0,82/0,59 630
50R P48 (H/V)	22,00/4,40	43/17,4	0,83/0,57 645

Motor 2 speed 400 V three-phase - 50 Hz 4/6 poles separate windings			
PYROSTAR® Model	Motor pwr. (kW)	Rated current (A)	Cos Weight (kg)
50R G46 (H/V)	2,20/0,65	5,5/2,5	0,80/0,73 540
50R H46 (H/V)	3,00/1,00	6,73/3,1	0,82/0,68 550
50R I46 (H/V)	4,20/1,25	9,2/5,1	0,86/0,67 570
50R J46 (H/V)	5,50/1,60	12/5,6	0,84/0,72 590
50R K46 (H/V)	7,50/2,20	14,65/5,8	0,86/0,73 610
50R M46 (H/V)	10,50/3,30	21,4/8,6	0,85/0,77 620
50R N46 (H/V)	14,5/4,40	28,1/11	0,86/0,75 630
50R O46 (H/V)	20,00/6,50	39/16	0,83/0,74 650
50R P46 (H/V)	23,00/7,20	43/15	0,88/0,87 665

The 250 and 200 dynamic pressures are the maximum pressures recommended for acceptable acoustic levels in comfort/smoke extraction applications.

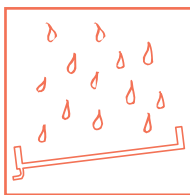
**REMOVAL OF CONDENSATES ref. ECP**

Located at the bottom of the unit, this condensate tray allows the **PYROSTAR®** unit to be used where there are special operational constraints, particularly in professional kitchens, etc. Order option PCB up to **PYROSTAR®** 12.

**ACOUSTIC INSULATION ref. IPH**

Very high density 25 mm - 120 kg/m<sup>3</sup> mineral wool providing powerful acoustic attenuation. See acoustic characteristics on page 237. Option F400-120/NFEN12101-3 approved by the CSTB. This option classifies the **PYROSTAR®**, range up to model 12 in the category of F400-120 THERMALLY INSULATED smoke extraction fans. Agréé et certifié par le CSTB. Approved and certified by the CSTB.

**DOUBLE SKIN INSULATION ref. IDP**

Insulation in 25mm - 60 kg/m<sup>3</sup> high density mineral wool. Internal face in 10/10 galvanized metal sheet. Internal face in 15/10 galvanized metal sheet. Meets the requirements of installations requiring regular maintenance of the unit and a significant reduction in radiated sound levels. This option classifies the **PYROSTAR®**, range up to model 12 in the category of F400-120 THERMALLY INSULATED smoke extraction fans. Approved and certified by the CSTB.

**FLEXIBLE SLEEVES ref. MTS — M0**

Fire classification M0. Flexible circular sleeves on intake and discharge sides for **PYROSTAR®** models 4 to 12. Flexible circular sleeves on intake and discharge sides for **PYROSTAR®** models 15 to 50.

**RAIN COWL ON OUTLET ref. RPP**

With safety and bird-protection mesh for **PYROSTAR®** 15 to 50..

**BIRD PROTECTION MESH ON OUTLET ref. GRE**

Option mandatory for outlet to the open air.

**SUPPORT FEET ref. PCB**

Set of 4 feet for **PYROSTAR®** models 4 to 12. Beyond this, the units are fitted with a strengthened chassis as standard.

**VIBRATION MOUNTS ref. PAV**

Mounts selected to exactly match each unit model. Four mounts up to **PYROSTAR®** model 20. Six mounts for all other models.

**CHAMFERED DUCT TERMINATION WITH MESH ref. BBG**

With safety and bird-protection mesh for **PYROSTAR®** 4 to 12.

ELECTRICAL  
OPTIONS **PYROSTAR****DIFFERENTIAL PRESSURE SWITCH ref. DEP**

**Function:** to detect a ventilation fault.  
 ✦ Factory-fitting to **PYROSTAR®** unit  
 Ⓜ 20 / NF EN 12101-3 approved

**SELF-REGULATING CONSTANT PRESSURE UNIT ref. LOBBY®**

**Function:** adapts the fan rotation speed instantaneously to the requirements of the installation. Energy savings of 30 to 60% and a reduction of sound levels radiated by the system.

✦ Factory wiring and fitting for LOBBY-T version F400-120 / NF EN 12101-3 approved for comfort/smoke extraction application.

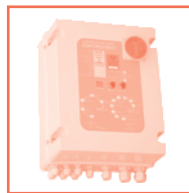
**RELAY UNIT ref. CDF**

**Function:** the CDF unit can be factory wired and fitted to the **PYROSTAR®** range.

**2-SPEED CONTROL BOX ref. CDA**

**Function:** controls and protects two-speed motors. DAHLANDER or SEPARATED WINDINGS, coupling with 24V local or remote control. Not compatible with the CDF unit.

- The box can be factory-fitted to the unit.

**SPEED CONTROLLER ref. VFM/T**

**VFM:** 230V single phase supply and 230V three-phase output for comfort application. Not compatible for connecting via the relay unit. The VFT speed controller must be used for this.

**VFT:** 400 V three phase supply and 400 V three-phase output for comfort/smoke extraction application.

✦ Factory fitting and wiring of the speed controller in the motor compartment of the **PYROSTAR®** unit with remote potentiometer F400-120 / NF EN 12101-3 approved.