

OPERATING AND COMMISSIONING INSTRUCTIONS



FREETIME[®]



HEXAMOTION[®]

OPERATING AND COMMISSIONING INSTRUCTIONS**SUMMARY**

I.	RECEIVING THE EQUIPMENT.....	4
I.1.	Checks on reception	4
I.2.	Unpacking	4
I.3.	Storing.....	4
I.1.	End of life	4
II.	INSTALLATION	5
II.1.	Handling.....	5
II.2.	Space required.....	5
II.2.a.	FREETIME®	5
II.2.b.	HEXAMOTION®	6
II.3.	Installation	6
III.	GENERAL FONCTIONNNG	9
III.1.	GENERAL	9
III.1.a.	FREETIME®	9
III.1.b.	HEXAMOTION®	9
III.2.	FUNCTIONNAL ANALYSIS	9
III.3.	MODE DE REGULATION	10
III.3.a.	SEASON :	10
III.3.b.	ECO :	10
III.3.c.	DIVA	10
III.3.d.	LOBBY® :	10
III.3.e.	MAC2® : (impossible with version FREETIME 500-800 et HEXAMOTION 05-08)	10
III.3.f.	QUATTRO® : (impossible with version FREETIME 500-800 et HEXAMOTION 05-08)	10
III.4.	COMPOSITION	11
III.4.a.	FREETIME®	11
III.4.b.	HEXAMOTION® FIRST-PREMIUM	12
III.4.c.	HEXAMOTION® SEASON	13
III.5.	ELEMENTS IN THE REGULATION	14
III.5.a.	FREETIME®	14
III.5.b.	HEXAMOTION®	15
IV.	ELECTRIC WIRING.....	16
IV.1.	POWER SUPPLY	16
IV.1.a.	FREETIME®	16
IV.1.b.	HEXAMOTION®	16
IV.2.	RACCORDEMENT SEASON	17
IV.3.	TEMPERATURE SENSOR WIRING (Except SEASON)	18
IV.4.	TERMINAL BLOCKS OF FREETIME® (Except SEASON)	18
IV.5.	Raccordement électrique et fonctionnement de l'échangeur rotatif	20
IV.5.a.	Version SEASON	20
IV.5.b.	Version FIRST PREMIUM	20
IV.6.	Filters pressure switches wiring and connection	22
IV.7.	Fan pressure switch wiring and connection	22
IV.8.	Pressure transmitters wiring and connection LOBBY®/MAC2®/QUATTRO®	22
IV.9.	Motors wiring	23
IV.10.	CO2 sensor wiring DIVA® QUATTRO®	23
IV.11.	Night Cooling	23
IV.12.	Hot water coil integrated (PREMIUM BC) – changeover water coil (PREMIUM CO) or external cold or changeover coil	24
IV.13.	DX battery (cold or reversible)	25

OPERATING AND COMMISSIONING INSTRUCTIONS

IV.14.	Electrical battery.....	25
IV.15.	Fire function.....	25
IV.16.	Dehumidification function.....	26
IV.17.	MODBUS / WEB / BACNET wiring.....	27
IV.18.	Repeater wiring	27
IV.19.	LON	28
V.	SETTINGS.....	28
V.1.	Display	28
V.2.	Exemple of setting	28
V.3.	Standard settings (opérateur menu).....	29
V.3.a.	Menu Mode de fonctionnement	30
V.3.b.	Temperature menu.....	31
V.3.c.	Ventilation menu	31
V.3.d.	Timer menu.....	32
V.4.	Operator parameters modification (password 3333 required).....	33
V.4.a.	Dates and hours clocks setting	33
V.4.b.	Speed /pressure modification in LS and HS.....	33
V.4.c.	Temperature setpoint modification	34
V.4.d.	Forced stop of the unit or forced start LS or HS on the remote control	34
V.4.e.	Choice of language	34
V.5.	Intermediate settings (service level)	34
V.5.a.	Menu configuration en accès service	35
V.6.	Modification of the services parameters (password 2222).....	35
V.6.a.	Regulation mode of the unit.....	35
V.6.b.	Overventilation parameters	35
V.6.c.	CO2 setpoint for DIVA / QUATTRO option	35
V.7.	Administrator settings	36
V.7.a.	Configuration menu with admin level access.....	36
V.8.	Modification of the service parameters	37
V.8.a.	MODBUS	37
VI.	REPAIR.....	39
VI.1.	Different types of defaults.....	39
VI.2.	List of alarms.....	39
VI.3.	Acknowledge the default « timer service »	41
VII.	MAINTENANCE	42
VII.1.	Obligatory maintenance	42
VII.2.	Battery replacement.....	42
VIII.	ANNEXES.....	44
VIII.1.	Command diagram	44
VIII.2.	Motors diagrams FREETIME® 500-800 HEXAMOTION® 05-08.....	45
VIII.3.	Motors diagrams FREETIME® 1500 HEXAMOTION® 15.....	46
VIII.4.	Motors diagrams FREETIME® 2000 HEXAMOTION® 20.....	47
VIII.5.	Motors diagrams FREETIME® 2700-3500 HEXAMOTION® 27-80	48
VIII.6.	Curves	49
VIII.6.a.	FREETIME®	49
VIII.6.b.	HEXAMOTION®	51
VIII.7.	MODBUS and BACNET tables	54
IX.	NOTES	57

OPERATING AND COMMISSIONING INSTRUCTIONS

SAFETY INSTRUCTIONS

In compliance with the current norms, the machine should be installed only by a technical person qualified for this type of work.

Use the required personal protection devices so as to avoid injuries caused by electrical and mechanical hazards (injuries by touching panels, sharp edges, etc.). Use EN170 protective eyewear and ear protection.

Do not use the unit for an other used which it designed. This unit can't be use for extract or supply dangerous air.

Move the machine as given in chapter *handling*.

Grounding is carried out in compliance with current standards. Never start the device without grounding

Before any intervention ensure that device is powered off and wait for complete stop of every rotative component such as damper, fan, rotative exchanger...

During device is running inspection doors must be mounted and closed.

Start is to be done only with padlockable swith.

Do not shut off or short circuit the safety and control equipment.

During interventions, be carefull with hot components such as hot water coil or electric resistances.

The machine should be installed in compliance with fire norms.

The waste must be disposed of in compliance with the current standards. No packaging should be discarded into the environment.

We disclaim any responsibility for any damages resulting from wrong utilisation of the equipment, reparation, modification or non compliance of these instructions.

I. RECEIVING THE EQUIPMENT

The units are delivered on stringers or palettes then wrapped in plastic film

I.1. Checks on reception

When the equipment is received, the state of the packaging and the equipment must be checked. In the event of damage, make an accurate note of any problems on the carrier's delivery note

I.2. Unpacking

When the equipment is unpacked, check the following:

- The total number of packages is present.
- All accessories are present (dampers, roof, electric switchgear, etc.). After unpacking the equipment, the waste must be disposed of in compliance with the current standards. No packaging should be discarded into the environment

I.3. Storing

The equipment must be stored in shade, in a dry place, at a temperature between -20°C and 40°C. The packaging can't be considered sufficient for an external storage.

I.1. End of life

In accordance with the partnerships with the compagny ECOLOGIC. CALADAIR fulfills the obligations to finance the collection, removal and treatment of Waste Electrical and Electronic Equipment.

At the end of the life of this equipment, the user contacts the company ECOLOGIC who will propose a collection solution or a place of deposit for the product.

Contacts for pick-up requests:

E-mail: operations-pro@ecologic-france.com

Phone: 01 30 57 79 14

Internet: www.e-dechet.com

OPERATING AND COMMISSIONING INSTRUCTIONS

II. INSTALLATION

II.1. Handling

The units must only be moved in their installation position.

If the device is handled using a fork-lift truck, ensure this supports the load-bearing structure

If the device is moved using a crane, use four cables of identical lengths. These must be at least as long as the greatest distance between two fastening points.

II.2. Space required

II.2.a. FREETIME®

Generally speaking, it is desirable to provide access space equal to L

Modèle FREETIME®	Ø	A	B	C	D	E	E1	E2	F	F1	G	J	J1	L	SEASON FIRST	PREMIUM BE PREMIUM BC
	mm	mm	mm	mm	mm	mm	mm	mm	mm	mm	mm	mm	mm	mm	kg	kg
500	200	900	570	970	145	205	195	205	135	155	385	75	130	520	130	135
800	250	1080	700	1090	170	235	240	260	160	235	485	75	180	650	170	175
1500	315	1400	750	1140	230	315	310	315	210	190	585	100	230	720	225	232
2000	355	1500	830	1220	250	335	330	335	230	230	660	100	230	770	270	278
2700	400	1610	920	1420	270	345	345	375	250	290	755	100	230	820	345	355
3500	450	1730	1085	1420	300	365	370	400	275	390	795	100	305	980	420	432

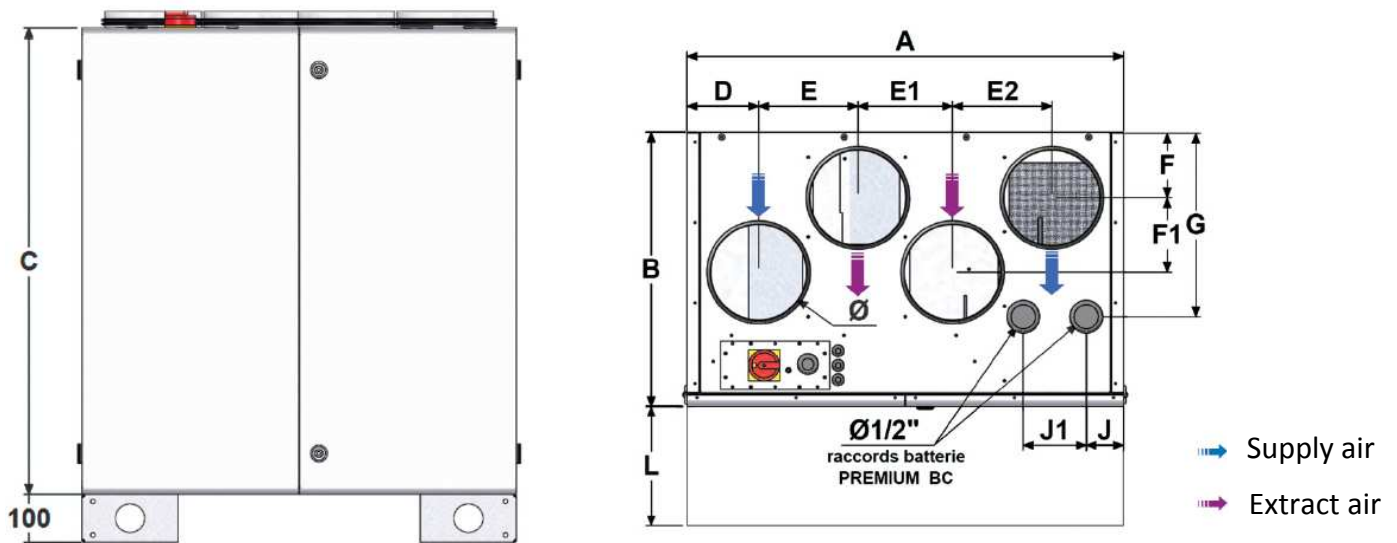

INDOOR INSTALLATION ONLY

OPERATING AND COMMISSIONING INSTRUCTIONS

II.2.b. HEXAMOTION®

Modèle HEXAMOTION®	Ø	A	A1	A2	B	B1	C	D	E	G	J	J1	J2	J3	L	M	M1	M2	T1*	T2** OUT	T3** IN	SEASON FIRST	PREMIUM BE	PREMIUM CO PREMIUM DXR
	mm	mm	mm	mm	mm	mm	mm	mm	mm	mm	mm	mm	mm	mm	mm	mm	mm	mm	EAU	DXR	DXR	kg	kg	kg
05	200	1215	-	-	675	620	805	305	350	95	245	-	-	375	555	180	820	-	1/2"	12	9,52	175	180	185
08	250	1345	-	-	805	750	925	335	410	95	250	-	-	430	620	310	950	-	1/2"	16	12	225	230	235
15	355	1500	-	-	805	750	925	335	425	95	250	-	-	430	700	310	1105	-	1/2"	16	12	245	255	260
20	400	1525	-	-	885	830	1005	355	465	95	250	-	-	470	710	390	1130	-	1/2"	18	12	280	290	300
27	450	1730	-	-	975	920	1205	405	550	95	250	-	-	570	745	480	1335	-	1/2"	22	16	360	375	385
35	500	1730	-	-	1140	1085	1205	405	565	95	250	-	-	570	910	645	1335	-	3/4"	22	16	420	435	450
45	630	1860	-	-	1265	1210	1495	475	715	105	250	405	475	715	1035	770	635	635	1"	20	12	510	530	545
60	630	2050	1045	1005	1465	1410	1495	475	715	105	250	405	475	715	1235	970	652	612	1"	22	16	650	675	690
80	-	2260	1155	1105	1545	1490	1645	-	-	105	250	435	515	790	1315	1050	762	712	1"	28	20	790	820	835

* Tube acier fileté gaz ** Tube cuivre

G-J-J3-T1: batterie à eau changeover (CO)

G-J-J1-J2-J3-T2-T3: batterie détente directe (DXR)

HEXAMOTION® 05-35

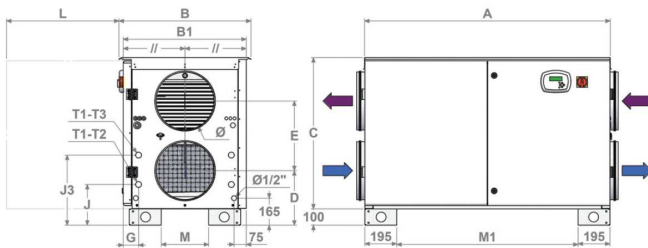

HEXAMOTION® 60

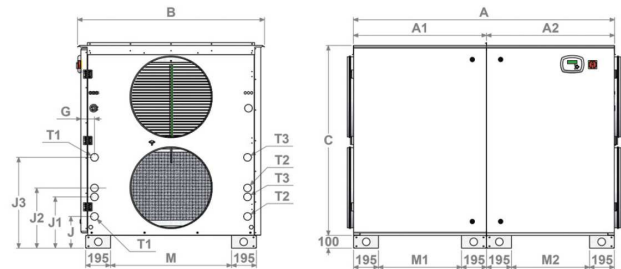

HEXAMOTION® 45

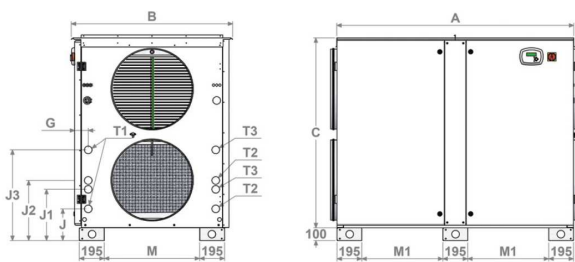

HEXAMOTION® 80

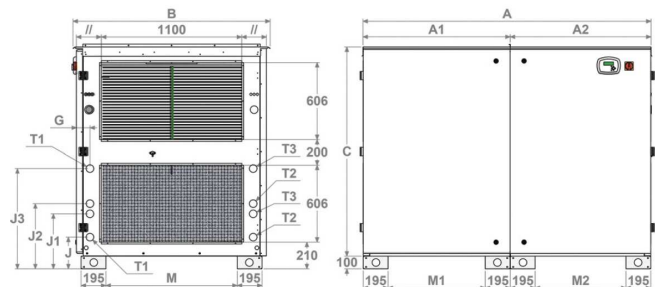

II.3. Installation

The unit must be laid on a sufficiently rigid and flat surface (use vibration mounts if necessary). For the HVAC connection, select duct sections based on dimensions of the flexible bands that should be properly stretched. Install the unit such that bad weather or ambient temperature cannot damage the internal items of the unit during installation as well as when used later

Provide a siphon on each condensate drainage pipe. A siphon can only be used for one drainage system. Note: the siphon must be connected in accordance with Best Practices in order that the condensates are removed as efficiently as possible.

The height H must be at least equal to the maximum internal negative pressure of the unit (Dp in mm).

Example : Dp = 500 Pa @ 50 mm CE

⇒ H > 50 mm 2H > 100 mm

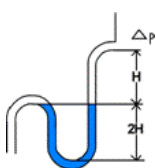

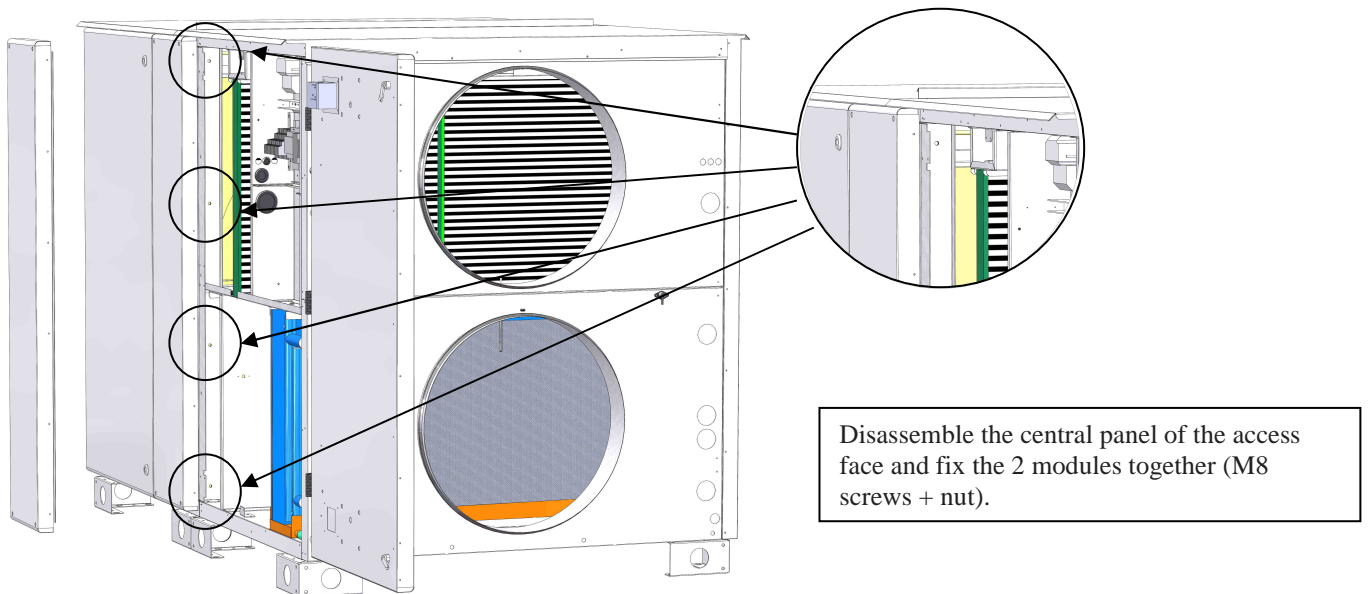
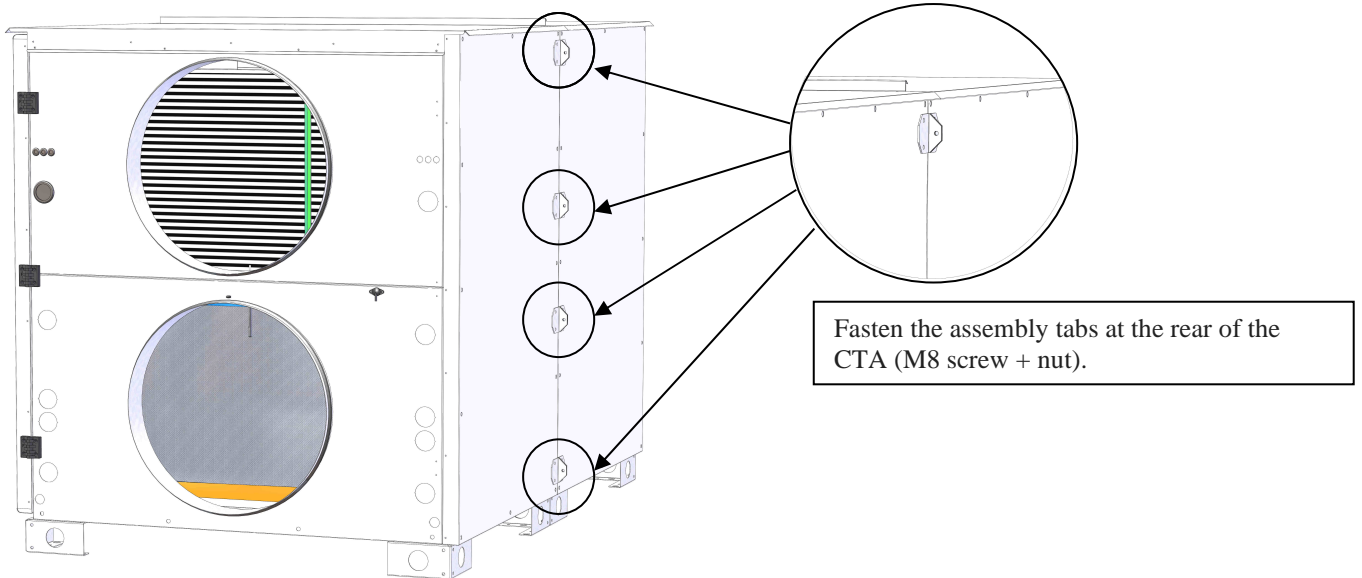
OPERATING AND COMMISSIONING INSTRUCTIONSHEXAMOTION[®] 60-80

OPERATING AND COMMISSIONING INSTRUCTIONS

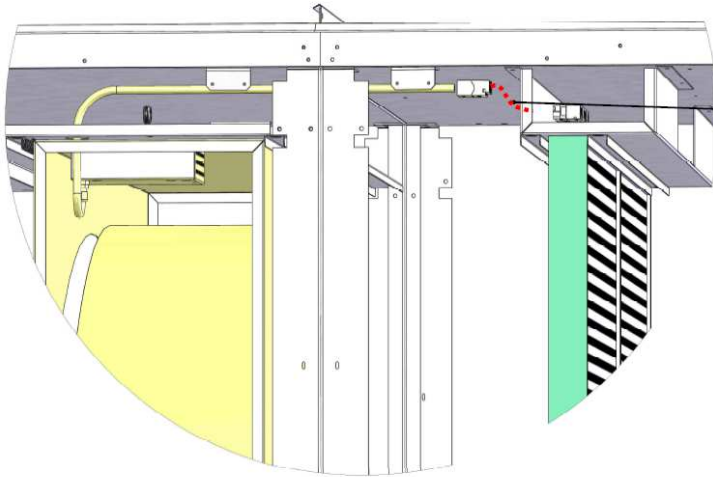

Connect the connectors between the 2 modules

Version FIRST-PREMIUM

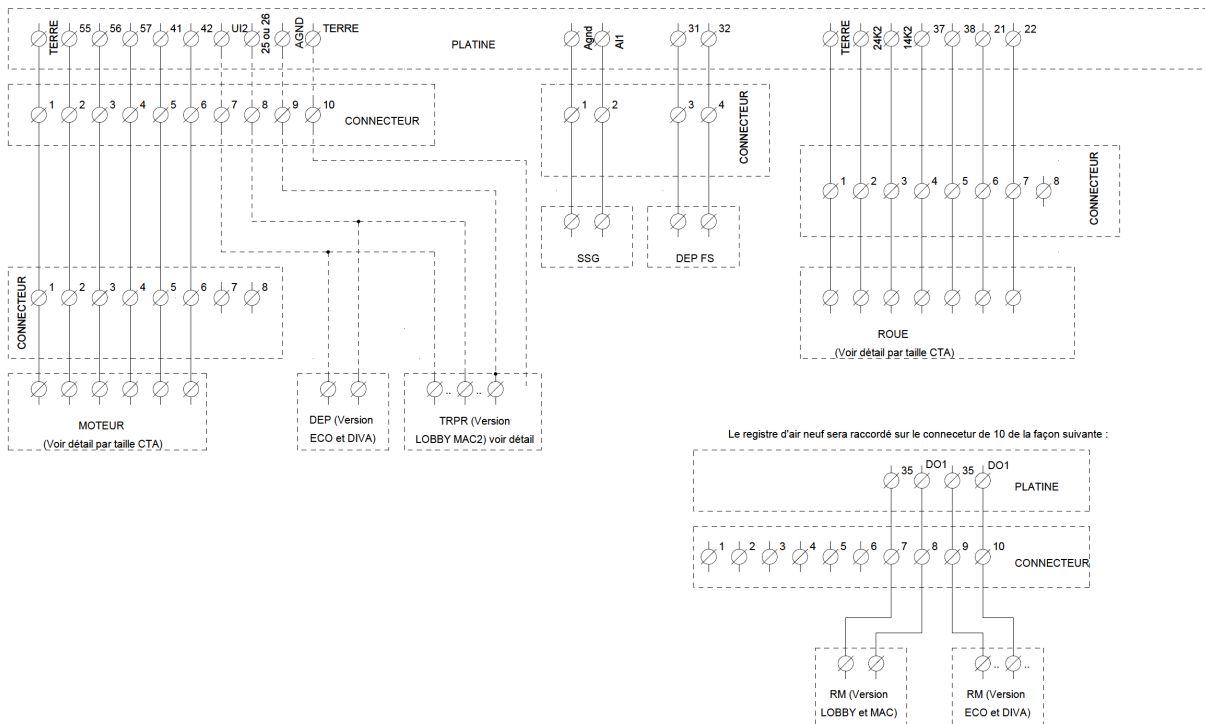

Version SEASON

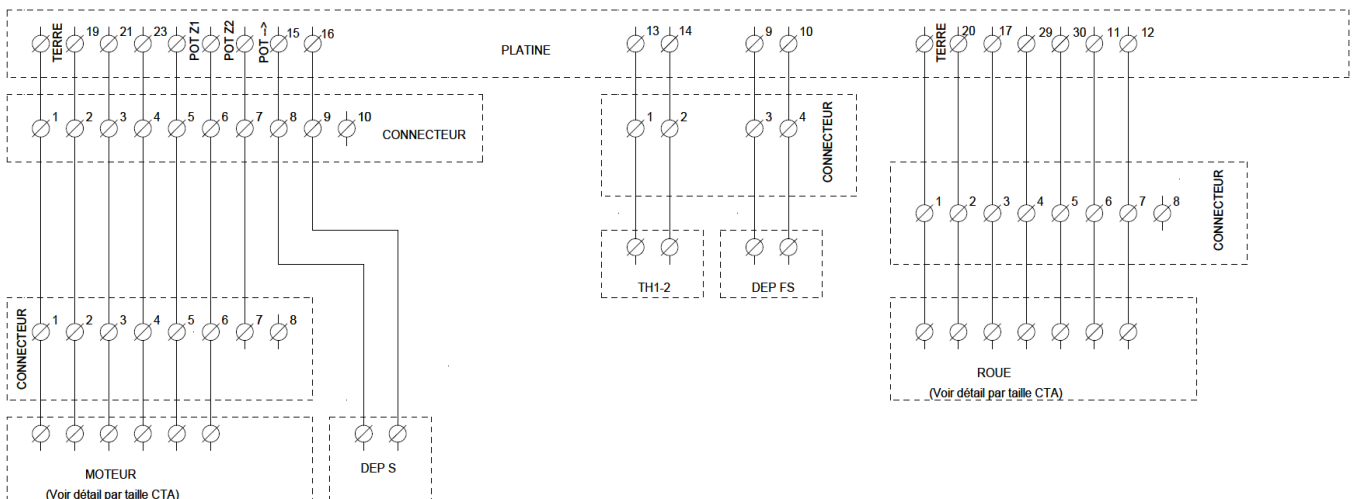

OPERATING AND COMMISSIONING INSTRUCTIONS

III. GENERAL FONCTIONNING

III.1.GENERAL

FREETIME® and **HEXAMOTION®** range are programme of double-flow units with high efficiency recovery, self-regulating recovery meant for office and industrial installations. Its performance is greater than 80%.

III.1.a. FREETIME®

FREETIME® SEASON : Manages the fans by potentiometers and rotative exchanger. No battery can be associated.

FREETIME® FIRST : Econological management of fans and rotative exchanger. Allows managing a non-integrated changeover battery or (hot water battery non-integrated or and cold water battery non integrated).

FREETIME® PREMIUM BC : Econological management of the fans, rotative exchanger and a hot water integrated battery. If required, it can also manage a non-integrated cold water battery.

FREETIME® PREMIUM BE : Econological management of the fans, rotative exchanger and an electrical integrated battery. If required, it can also manage a non-integrated cold water battery.

III.1.b. HEXAMOTION®

HEXAMOTION® SEASON : Manages the fans by potentiometers and rotative exchanger. No battery can be associated.

HEXAMOTION® FIRST : Econological management of fans and rotative exchanger. Allows managing a non-integrated changeover battery or (hot water battery non-integrated or and cold water battery non integrated).

HEXAMOTION® PREMIUM CO : Econological management of the fans, rotative exchanger and a changeover water integrated battery. If required, it can also manage a non-integrated cold water battery.

HEXAMOTION® PREMIUM BE : Econological management of the fans, rotative exchanger and an electrical integrated battery. If required, it can also manage a non-integrated cold water battery.

HEXAMOTION® PREMIUM DXR : Econological management of the fans, rotative exchanger and an reversible direct expansion battery.

III.2.FUNCTIONNAL ANALYSIS

Except SEASON version

Starting sequence :

- The supply air fan starts and the fresh air register opens.
- The extract air fan starts and the extract air register opens
- Temperature regulation starts defined in the regulation mode set. Electric heater (if set), starts with airflow controller. Pumps start.
- After a defined time, alarms management function is activated. Installation is in normal mode.

Start conditions :

Installation starts when one of these conditions are filled:

- Timer normal or reduced are activate
- Manual start is activated with controller
- One of the digital input for extended operation is activated.

Stop sequence :

Installation stops with following process:

- Deactivation of the alarm management function.
- Electric heater stops (if set).
- After a defined time (individually defined for each fan) fans are stopped.
- Supply and return air registers are closed .
- Signals toward actuator are reset and pumps closed

Stop conditions :

Installation stops when one these conditions are filled:

- Timers normal or reduced are not activated and digital input for extended operation is not activated.
- Digital Input for External stop is activated.
- Manual stop is activated with controller
- An alarm configured with stop function is activated. Installation will automatically start when alarm is reset.

OPERATING AND COMMISSIONING INSTRUCTIONS

III.3. MODE DE REGULATION

III.3.a. SEASON :

1 Adjustable speeds from potentiometers

Each fan is individually adjustable from integrated potentiometer.
Possibility to add a remote forced stop (in standard on supply contactor (not supplied))

III.3.b. ECO :

1 or 2 speeds adjustable « MODE VENTIL (%) »

Adjustment of a minimum speed (LS - 1/2) and a maximum speed (HS - 1/1) in %.
Fitted with a factory turned clocked set :

- (HS - 1/1) from 06h00 to 22h00
- (LS - 1/2) from 22h00 to 06h00

Possibility of adding a remote forced start (LS - 1/2) or (HS - 1/1) (free voltage contact NO)
Possibility of adding a remote forced stop (free voltage contact NO)

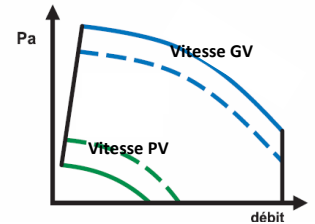

III.3.c. DIVA

Proportional ventilation between two airflows (LS/HS) with CO2 management « AUTO CO2 MODE »

Adjustment of a minimum speed (LS - 1/2) and a maximum speed (HS - 1/1) in %.
CO2's setpoint is set in factory to 1000ppm (compliant to French RT2012).
Variation between (LS - 1/2) and (HS - 1/1) is managed from CO2 level
Fitted with a factory turned clocked set in (LS - 1/2) from 00h00 to 24h00.
Possibility of adding a remote forced start (LS - 1/2) or (HS - 1/1) (free voltage contact NO)
Possibility of adding a remote forced stop (free voltage contact NO)

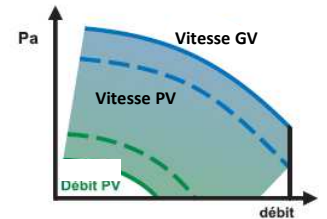

Nota : In order for the CO2 regulation works, installation must follow these constraints :



- Clock (HS - 1/1) is not activated (normal speed timer)
- Clock (LS - 1/2) is activated (reduced speed Timer)
- External operation (HS - 1/1) and external stop are not activated.

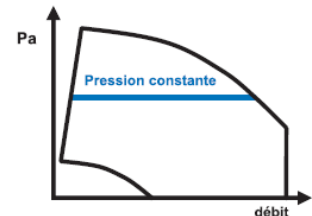

III.3.d. LOBBY® :

Constant pressure ventilation. (Pa) « CONSTANT PA MODE»

Constant pressure adjustment (Pa).
Fitted with a factory turned clocked set in (LS - 1/2) from 00h00 to 24h00.
Possibility of adding a remote forced start (LS - 1/2) (free voltage contact NO)
Possibility of adding a remote forced stop (free voltage contact NO)

III.3.e. MAC2® : (impossible with version FREETIME 500-800 et HEXAMOTION 05-08)

1 or 2 constant air flow (m³/h) adjustable « MODE CONSTANT M3/H »

Adjustment of a minimum constant air flow (LS - 1/2) and a maximum air flow (HS - 1/1) in m3/h.
Fitted with a factory turned clocked set :

- (HS - 1/1) from 06h00 to 22h00
- (LS - 1/2) from 22h00 to 06h00

Possibility of adding a remote forced start (LS - 1/2) or (HS - 1/1) (free voltage contact NO)
Possibility of adding a remote forced stop (free voltage contact NO)

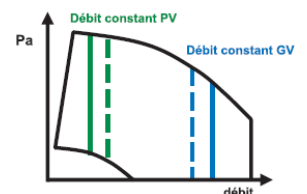

III.3.f. QUATTRO® : (impossible with version FREETIME 500-800 et HEXAMOTION 05-08)

Proportional ventilation between two constant airflows (m³/h) adjustable with CO2 management

Adjustment of a minimum constant air flow (LS - 1/2) and a maximum air flow (HS - 1/1) in m3/h.
CO2's setpoint is set in factory to 1000ppm (compliant to French RT2012).
Variation between (LS - 1/2) and (HS - 1/1) is managed from CO2 level
Fitted with a factory turned clocked set in (LS - 1/2) from 00h00 to 24h00.
Possibility of adding a remote forced start (LS - 1/2) or (HS - 1/1) (free voltage contact NO)
Possibility of adding a remote forced stop (free voltage contact NO)

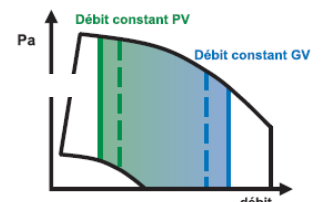

Nota : In order for the CO2 regulation works, installation must follow these constraints :

OPERATING AND COMMISSIONING INSTRUCTIONS



- Clock (HS - 1/1) is not activated (normal speed timer)
- Clock (LS - 1/2) is activated (reduced speed Timer)
- External operation (HS - 1/1) and external stop are not activated.

III.4.COMPOSITION

III.4.a. FREETIME®

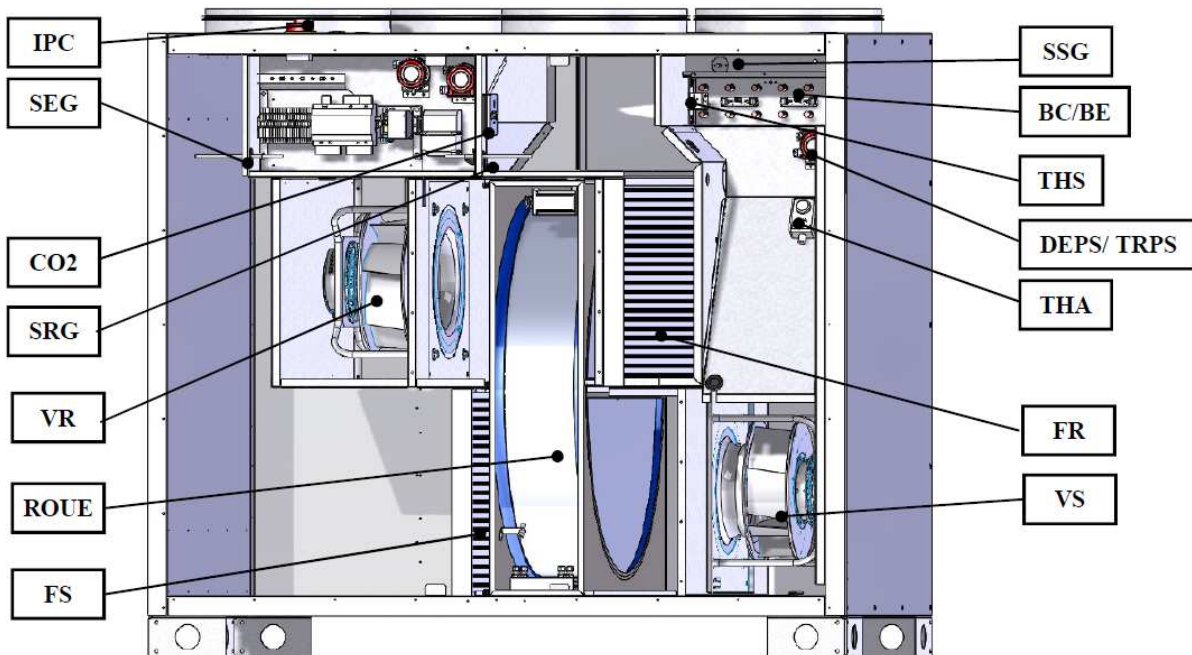

Nom	Détails
IPC	Padlockable switch
VS	Supply air fan
VR	Extract air fan
CO2*	CO2 sensor (DIVA®-QUATTRO® only)
SEG*	Outdoor temperature sensor
SRG*	Extract temperature sensor
SSG*	Supply temperature sensor
FS	Supply filter
FR	Extract filter
DEPS / TRPS	Supply pressure switch or supply pressure transmitter for version LOBBY®-MAC2®-QUATTRO®
THA*	External fros guard (version PREMIUM BC)
THS*	Overheat security thermostat (version PREMIUM BE)
BC/BE*	Hot water coil or electrical battery (see version)
ROUE	Rotative exchanger with rotative sentinel included

*components non included in SEASON version

OPERATING AND COMMISSIONING INSTRUCTIONS

III.4.b. HEXAMOTION® FIRST-PREMIUM

05-45

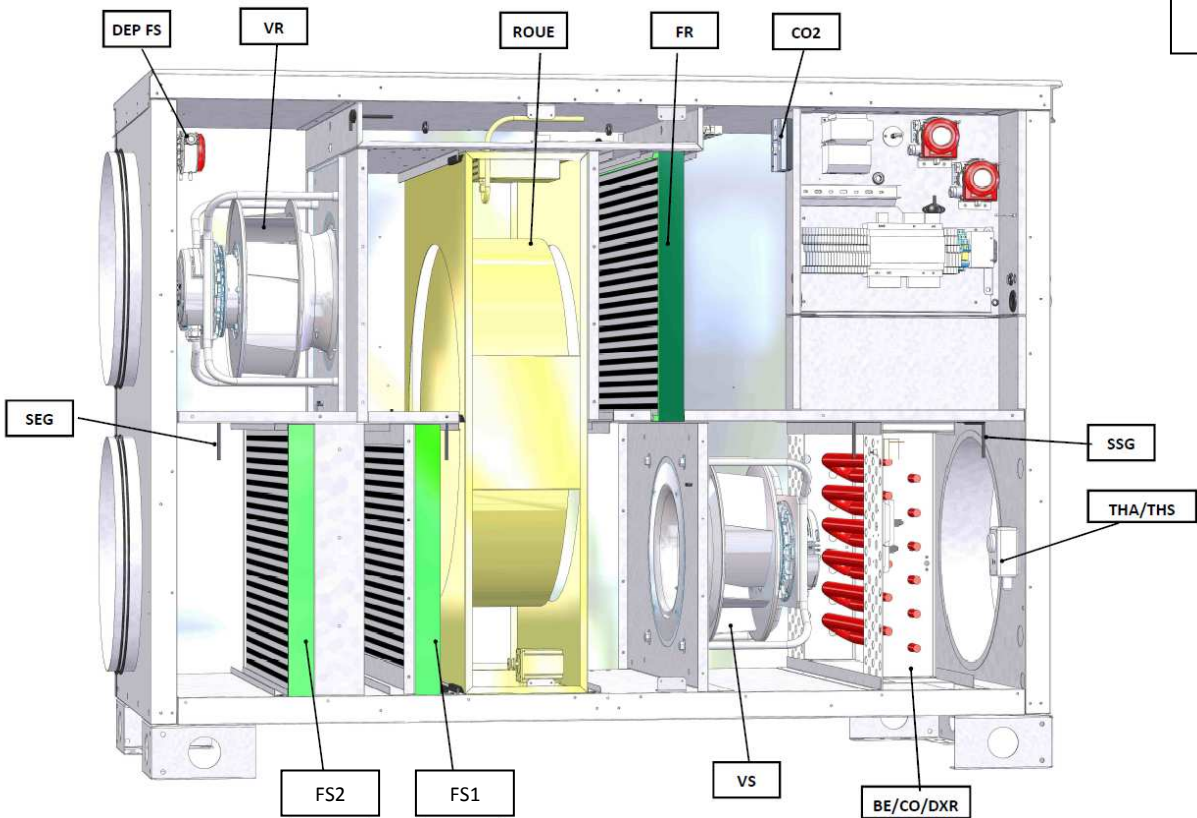

60-80

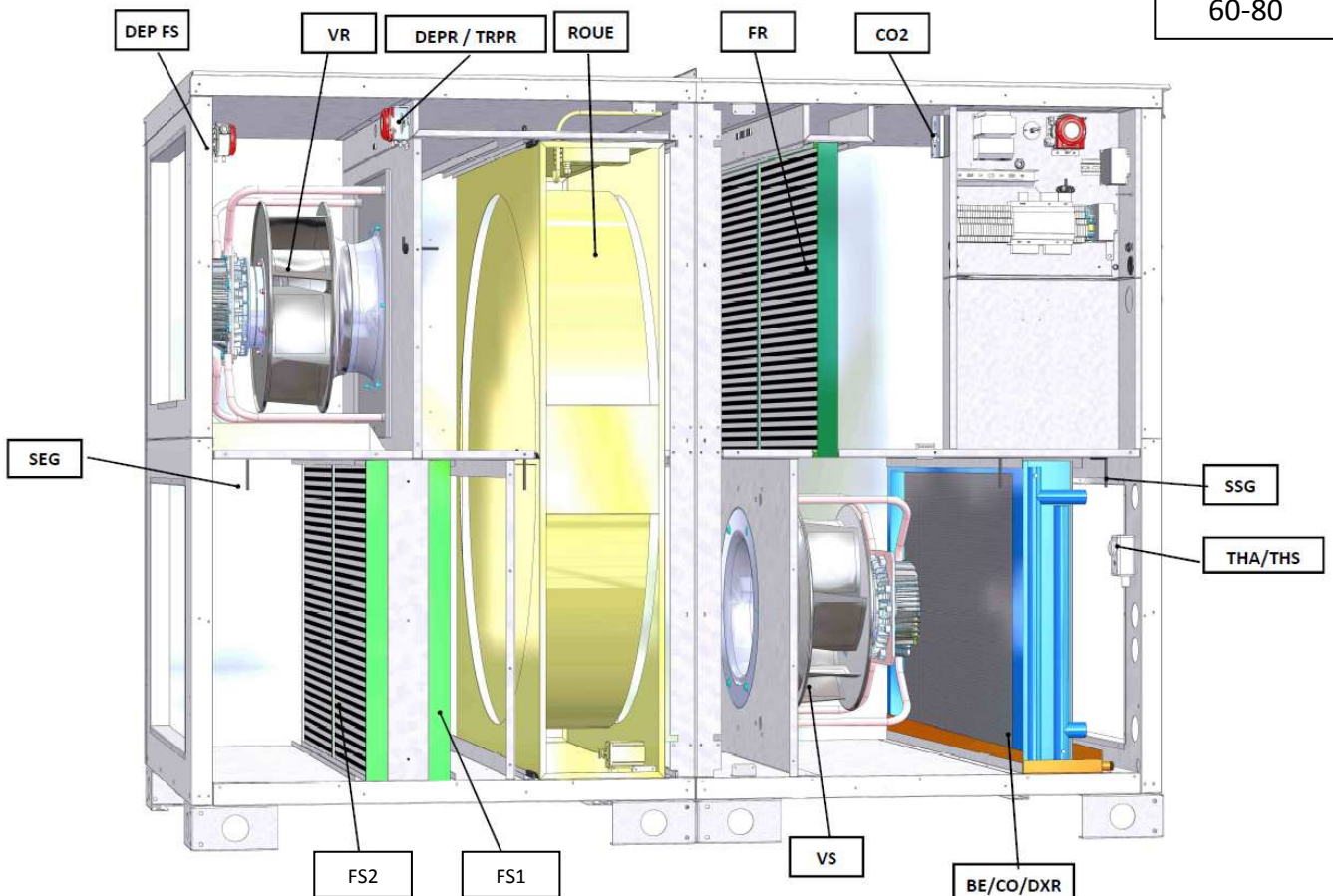

OPERATING AND COMMISSIONING INSTRUCTIONS

Nom	Détails
VS	Supply air fan
VR	Extract air fan
CO2*	CO2 sensor (DIVA [®] -QUATTRO [®] only)
SEG*	Outdoor temperature sensor
SSG*	Supply temperature sensor
FS1	Supply filter 1
FS2	Supply filter 2 (OPTION)
DEPFS	Filter guard pressure switch
FR	Extract filter
DEPR / TRPR	Extract pressure switch or extract pressure transmitter for version LOBBY [®] -MAC2 [®] -QUATTRO [®]
THA	External fros guard (version PREMIUM CO)
THS	Overheat security thermostat (version PREMIUM BE)
BC/BE/DXR	Hot water coil or electrical battery (see version)
ROUE	Rotative exchanger with rotative sentinel included

III.4.c. HEXAMOTION[®] SEASON

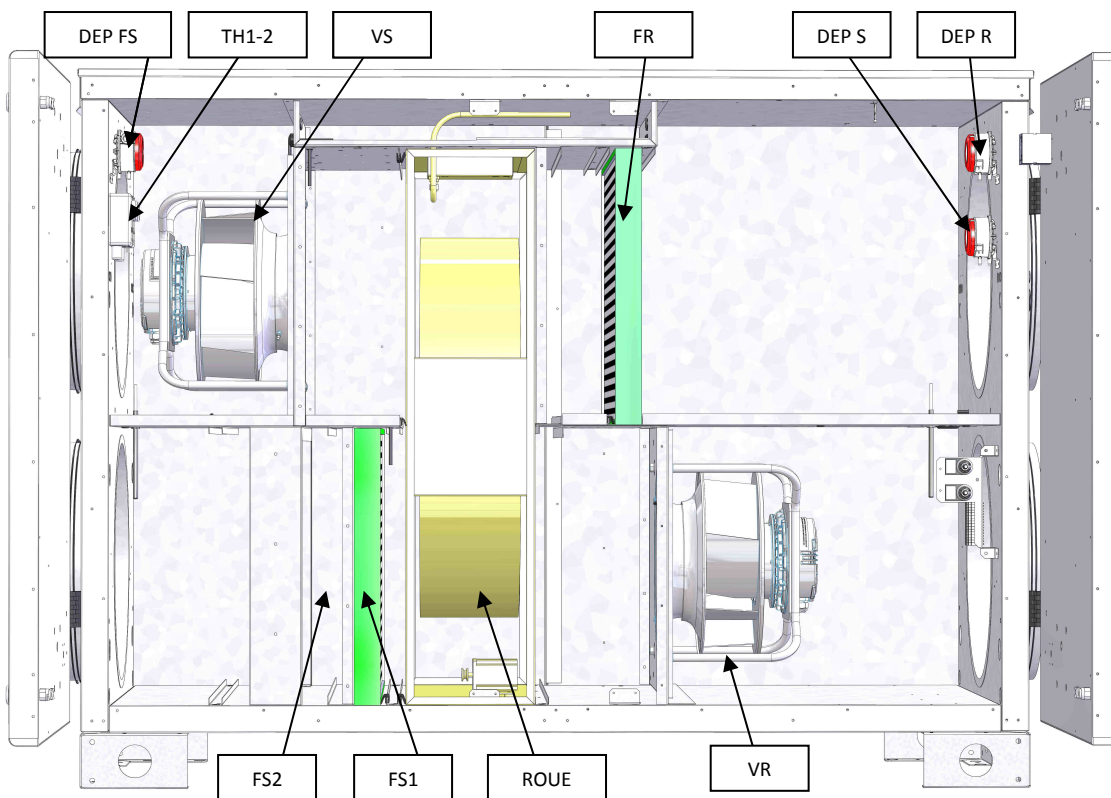

Nom	Détails
VS	Supply air fan
VR	Extract air fan
FS1	Supply filter 1
FS2	Supply filter 2 (OPTION)
DEPFS	Filter guard pressure switch
DEPR	Extract pressure switch
DEPS	Supply pressure switch
TH1-2	Thermostat for Bypass
ROUE	Rotative exchanger with rotative sentinel included

OPERATING AND COMMISSIONING INSTRUCTIONS

III.5. ELEMENTS IN THE REGULATION

III.5.a. FREETIME®

III.5.a.1. REGULATION ECO/DIVA/LOBBY

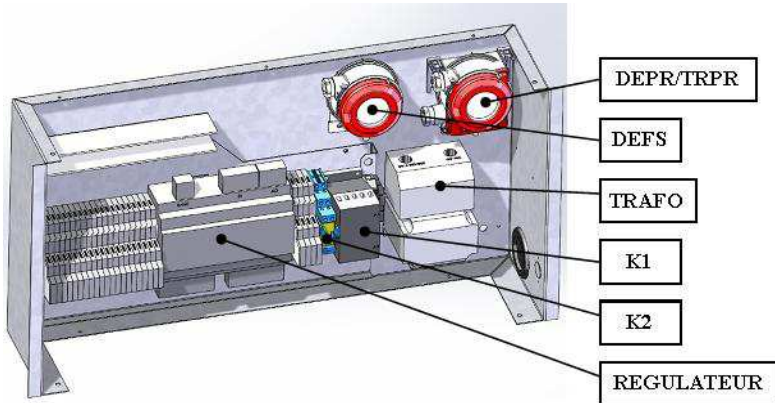

Nom	Détails
DEPFS	Filter pressure switch
DEPS ou TRPS	Extract pressure switch or extract pressure transmitter for version LOBBY®-MAC2®-QUATTRO®
TRAFO	Transformer 230/24V
K1	Contacteur of electric battery heater
K2	Rotative exchanger relay
REGULATEUR	CORRIGO E283W3 controller

III.5.a.2. REGULATION SEASON

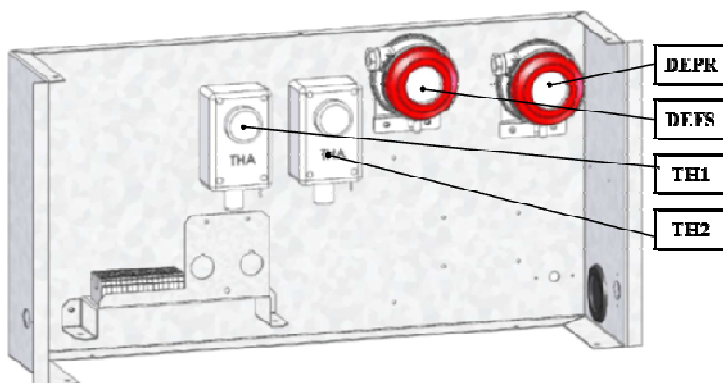

Nom	Détails
DEPFS	Filter pressure switch
DEPR	Extract pressure switch
TH2	Summer setpoint thermostat for start rotative exchanger
TH1	Winter setpoint thermostat for start rotative exchanger

OPERATING AND COMMISSIONING INSTRUCTIONS

III.5.b. HEXAMOTION®

III.5.b.1. REGULATION ECO/DIVA®/LOBBY®/MAC2®/QUATTRO®

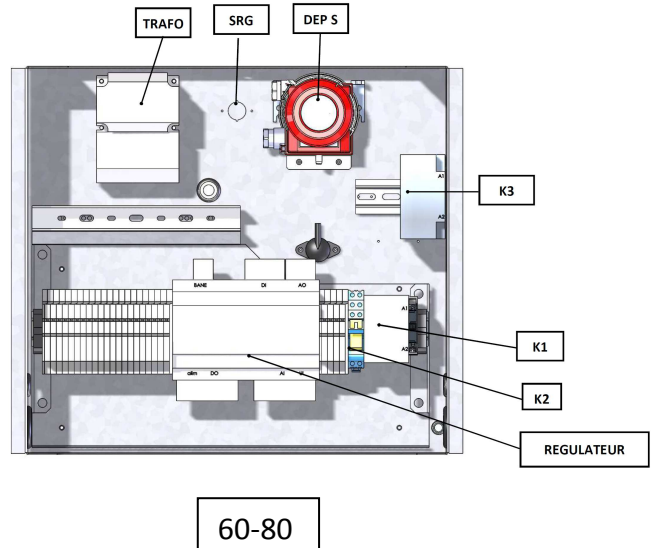
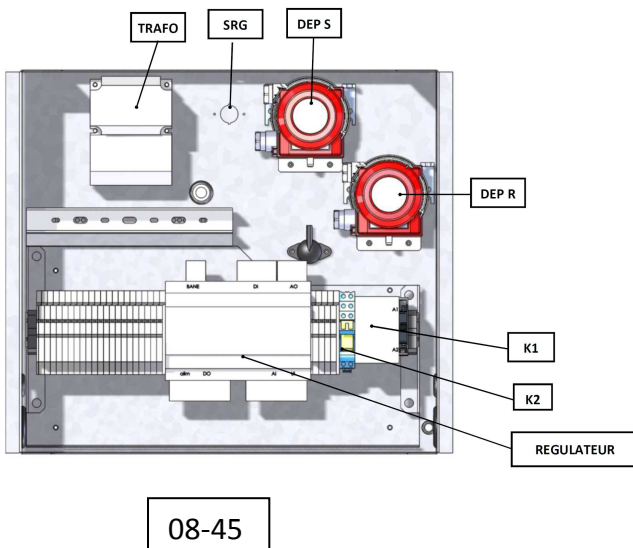

Nom	Détails
DEPS ou TRPS	Supply pressure switch or extract pressure transmitter for version LOBBY®-MAC2®-QUATTRO®
DEPR ou TRPR	Extract pressure switch or extract pressure transmitter for version LOBBY®-MAC2®-QUATTRO® (05-45 only)
TRAF0	Transformer 230/24V
K1	Contacteur of electric battery heater
K2	Rotative exchanger relay
K3	Contacteur of electric battery heater (Step 2 = 60-80)
REGULATEUR	CORRIGO E283W3 controller

III.5.b.2. REGULATION SEASON

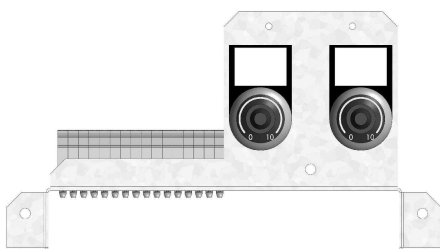

Nom	Détails
POTS	Potentiometer supply air fan
POTR	Potentiometer extract air fan

OPERATING AND COMMISSIONING INSTRUCTIONS

IV. ELECTRIC WIRING

IV.1. POWER SUPPLY

IV.1.a. FREETIME®

Modèle FREETIME®	Puissance moteur électrique (W)	Temp. Utilisation (°C / °C)	Indice de protection Classe	Protection thermique *	SEASON/FIRST & PREMIUM BC		PREMIUM BE	
					Tension alimentation (V / Ph / Hz)	Intensité de protection (A)	Tension alimentation (V / Ph / Hz)	Intensité de protection (A)
500	2 x 169 W	-20 / 60	IP54 / B	PTI	230 / 1 / 50	3,8	230 / 1 / 50	14,7
800	2 x 220 W	-20 / 60	IP44 / B	PTI	230 / 1 / 50	4,1	230 / 1 / 50	20,4
1500	2 x 750 W	-20 / 40	IP54 / B	PTI	230 / 1 / 50	7,6	230 / 1 / 50	30,4
2000	2 x 750 W	-20 / 40	IP54 / B	PTI	230 / 1 / 50	7,6	400 /3+N / 50	18,5
2700	2 x 1000 W	-20 / 50	IP54 / B	PTI	400 /3+N / 50	4,3	400 /3+N / 50	23,8
3500	2 x 1000 W	-20 / 50	IP54 / B	PTI	400 /3+N / 50	4,3	400 /3+N / 50	28,1

* PTI : Protection thermique intégrée

IV.1.b. HEXAMOTION®

Modèle HEXAMOTION®	Puissance moteur électrique (W)	Temp. Utilisation (°C / °C)	Indice de protection Classe	Protection thermique *	SEASON/FIRST & PREMIUM CO&DXR		PREMIUM BE	
					Tension alimentation (V / Ph / Hz)	Intensité de protection (A)	Tension alimentation (V / Ph / Hz)	Intensité de protection (A)
05	2 x 169 W	-20 / 60	IP54 / B	PTI	230 / 1 / 50	3,8	230 / 1 / 50	14,7
08	2 x 220 W	-20 / 60	IP44 / B	PTI	230 / 1 / 50	4,4	230 / 1 / 50	20,7
15	2 x 480 W	-20 / 40	IP54 / B	PTI	230 / 1 / 50	5,3	230 / 1 / 50	28,1
20	2 x 750 W	-20 / 40	IP54 / B	PTI	230 / 1 / 50	7,6	400 /3+N / 50	18,5
27	2 x 1000 W	-20 / 50	IP54 / B	PTI	400 /3+N / 50	4,3	400 /3+N / 50	23,8
35	2 x 1000 W	-20 / 50	IP54 / B	PTI	400 /3+N / 50	4,3	400 /3+N / 50	28,1
45	2 x 1700 W	-20 / 40	IP54 / B	PTI	400 /3+N / 50	6,2	400 /3+N / 50	40,9
60	2 x 1950 W	-20 / 50	IP54 / B	PTI	400 /3+N / 50	7,3	400 /3+N / 50	59,3
80	2 x 2730 W	-20 / 60	IP55 / F	PTI	400 /3+N / 50	9,4	400 /3+N / 50	78,7

* PTI : Protection thermique intégrée

OPERATING AND COMMISSIONING INSTRUCTIONS

IV.2. RACCORDEMENT SEASON

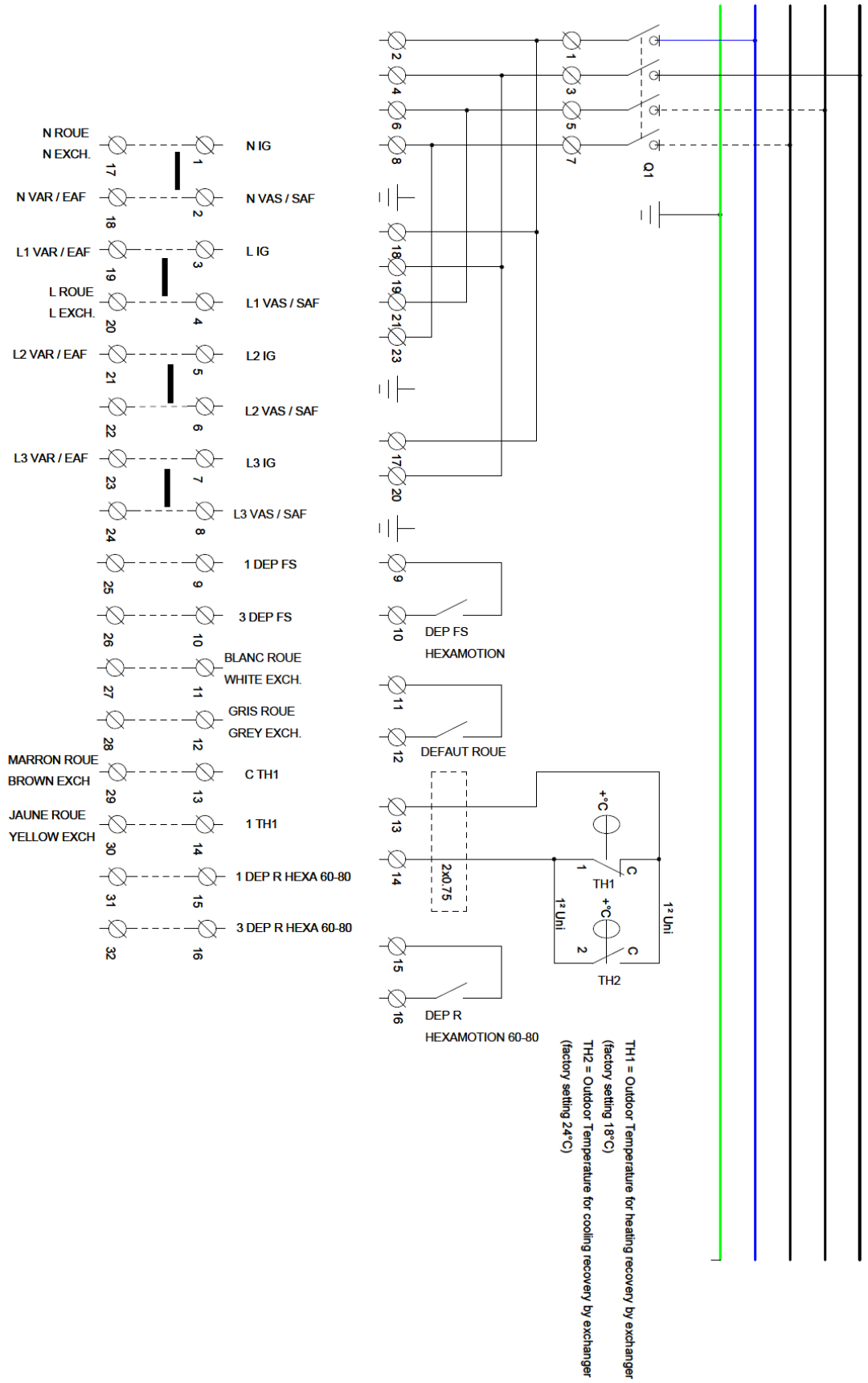

OPERATING AND COMMISSIONING INSTRUCTIONS

IV.3. TEMPERATURE SENSOR WIRING (Except SEASON)

Temperature sensors are connected on the controller

- **SSG** : Supply temperature sensor on Agnd(30) and AI1(31)
- **SEG** : Outdoor temperature sensor on Agnd(30) et AI2(32)
- **SRG** : Extract temperature sensor on Agnd(33) et AI3 (34)

IV.4. TERMINAL BLOCKS OF FREETIME® (Except SEASON)

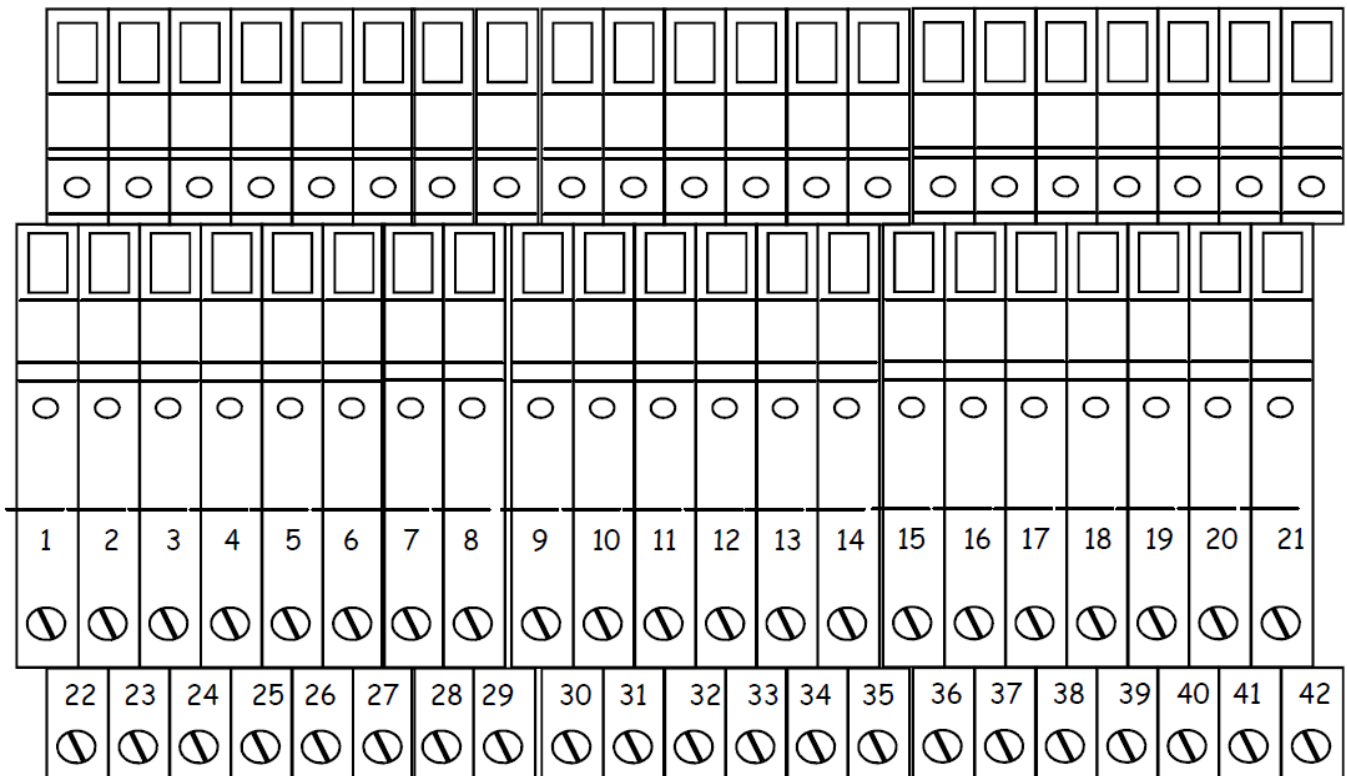

Désignation	Bornes	Raccordement
ADP (shunted if not used)	1-2	Connect on fire emergency stop (free voltage NC contact)
DAD (shunted if not used)	3-4	Connect on DAD (smoke detector) default contact (NC)
THA/THS (shunted if not used)	5-6	Connect to NC free voltage contact of THA (PREMIUM BC - CO) Or Connect to NC free voltage contact of THS (PREMIUM BE)
ED-TOUCH	7-8 + A*-B* (port2)	Connect to remote touch screen display
MF PV	9-10	Connect to NO free voltage contact of reduced Speed extended operation
MF GV	11-12	Connect to NO free voltage contact of normal Speed extended operation
ARR EXT	13-14	Connect to NO free voltage contact of external stop

OPERATING AND COMMISSIONING INSTRUCTIONS

BC	15-16-17	BC :Connect to 3 ways valve of the hot water battery (cf chapter IV.12)
BE	18 + DO3**	BE : Connect to static contactor of the electric battery (see chapter IV.14)
Heating pump (PREMIUM BC)	18 + DO3**	Connect to hot water circulator (Note : 24V 2AMax to relay) (see chapter IV.12)
Cooling pump	19 + DO4**	Connect to cold water circulator (Note : 24V 2AMax to relay)(see chapter IV.12)
AL	20 + DO5**	24V output available if unit is in default (Note : 24V 2A Max to relay)
NC (Night cooling) (LOBBY[®])	22 + DO7**	24V output available if unit runs with the optional LOBBY EC for opening dampers during Night Cooling. (pay attention : 24V 2A Max to relay)
TRPS	23 / Agnd* + UI1*	Connect to supply Pressure T ransmitter (see chapter IV.8)
DEPS	24 + UI1*	Connect to terminal 1 and 3 of supply pressure switch (see chapter IV.7)
TRPR	25 / Agnd* + UI2*	Connect to return pressure T ransmitter (see chapter IV.8)
DEPR	26 + UI2*	Connect to terminal 1 and 3 of return pressure switch (see chapter IV.7)
CO2	27 / Agnd* UI3*	Connect to CO2 sensor (see chapter IV.10) DIVA/QUATTRO option
BF	28-29-30	BF :Connect to 3 ways valve of the cold water battery (see chapter IV.12)
DEP FS DEP FR	31-32 33-34	Connect to terminal of exhaust filter switch (see chapter IV.6) Connect to terminal 1 and 3 of return filter switch (see chapter IV.6)
RMS	35 + DO1**	Connect to fresh air damper actuator
RMR	36 + DO2**	Connect to extract air damper actuator
ROUE	37-38 and 21-22	Rotative exchanger wiring (Cf IV.5)
0-10V S	39-40	Connect to Supply air fan (cf chapter VIII.2 and 5)
0-10V R	41-42	Connect to Extract air fan (cf chapter VIII.2 and 5)

*A raccorder directement sur régulateur CORRIGO

** A raccorder directement sur régulateur CORRIGO et 8A max sur l'ensemble des DO

OPERATING AND COMMISSIONING INSTRUCTIONS

IV.5. Raccordement électrique et fonctionnement de l'échangeur rotatif

IV.5.a. Version SEASON

Rotative exchanger is factory wired

Son fonctionnement est automatique grâce à deux thermostats :

It automatically runs with two thermostats:

In winter: if outside intake air is lower to 18°C (adjustable), The rotative exchanger starts to recover maximum calories.

In summer:

COLD RECOVERY : if outside intake air is higher to 24°C (adjustable), The rotative exchanger starts to recover maximum of calories.

FREE COOLING : if outside temperature is between 24° et 18° (adjustable) The rotative exchanger stops to bring directly outside fresh air

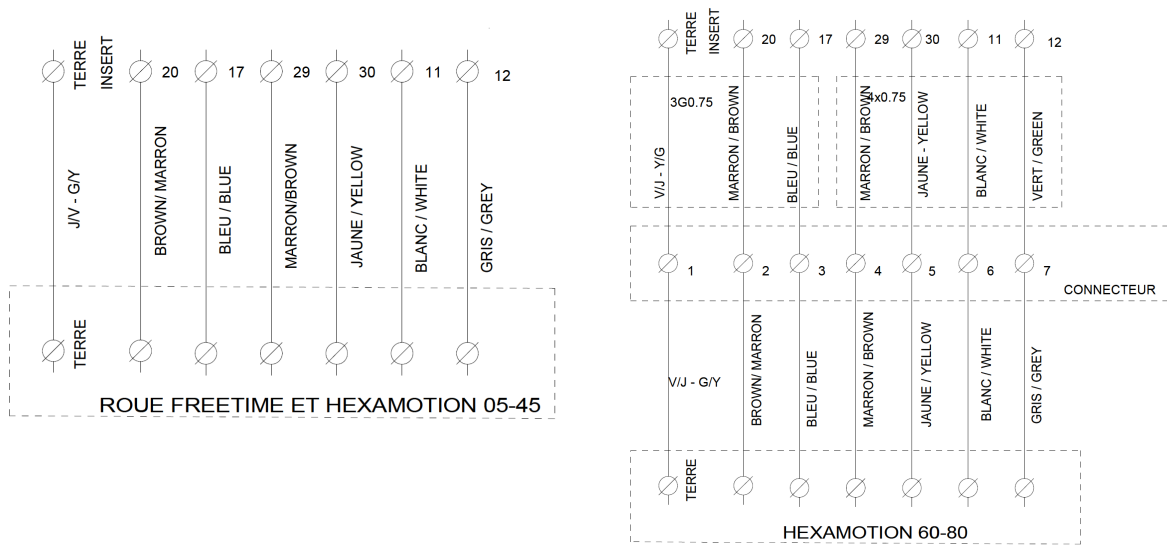

IV.5.b. Version FIRST PREMIUM

Rotative exchanger is factory wired

CORRIGO controller drives automatically the bypass thanks to programmation and sensor mounted in standard on FREETIME units.

In winter: when heat is needed, The rotative exchanger starts to recover maximum of calories. If it is not enough to reach the temperature setpoint, hot battery starts running.

In summer :

COLD RECOVERY : if outside temperature is higher than inside temperature and cold is needed , The rotative exchanger starts to recover maximum of calories. If it is not enough to reach the setpoint, cold battery starts running.

FREE COOLING : if outside temperature is lower than inside temperature and cold is needed , The rotative exchanger stops to bring directly outside fresh air. If it is not enough to reach temperature setpoint cold battery starts running.

OPERATING AND COMMISSIONING INSTRUCTIONS

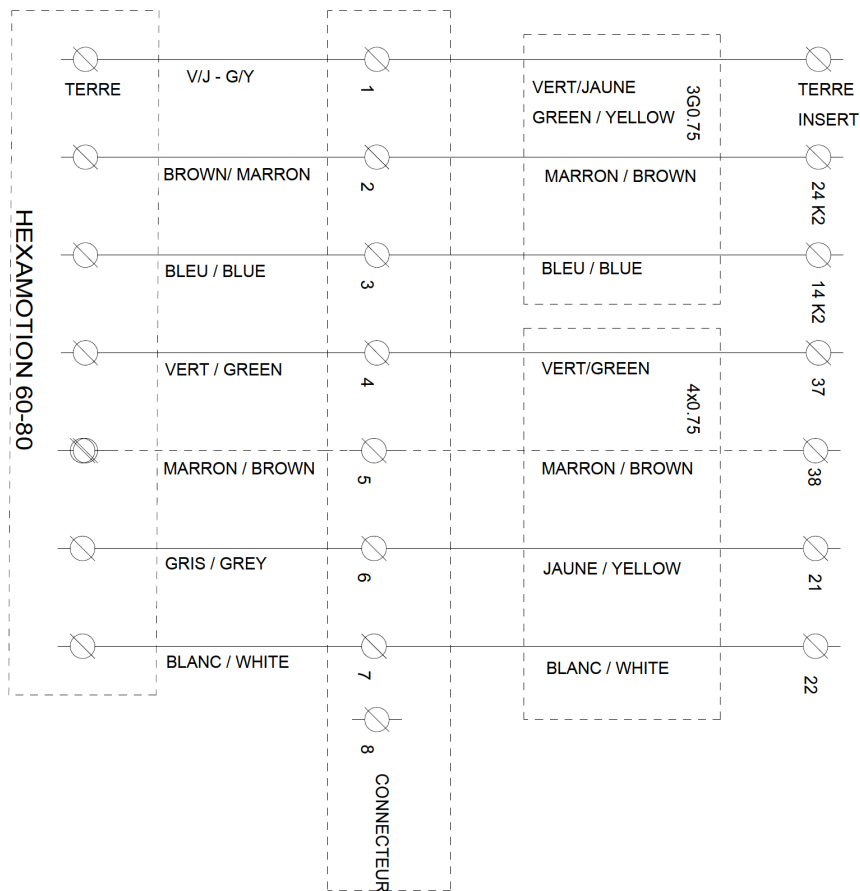
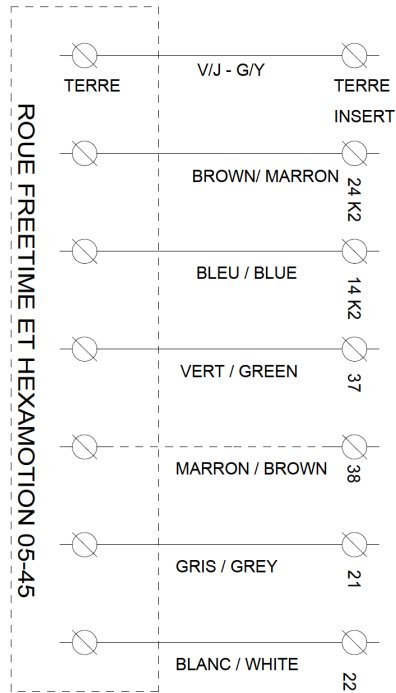

OPERATING AND COMMISSIONING INSTRUCTIONS

IV.6. Filters pressure switches wiring and connection

Le pressostat filtre air neuf est câblé et raccordé d'usine

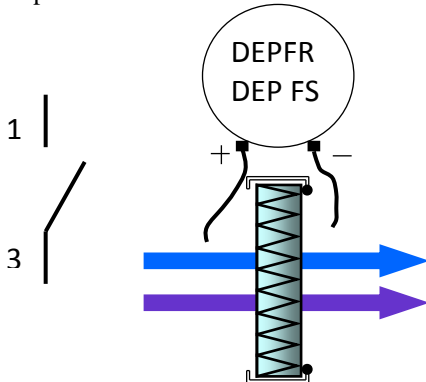

IV.7. Fan pressure switch wiring and connection

Les pressostats ventilateurs sont câblés et raccordés aérauliquement d'usine

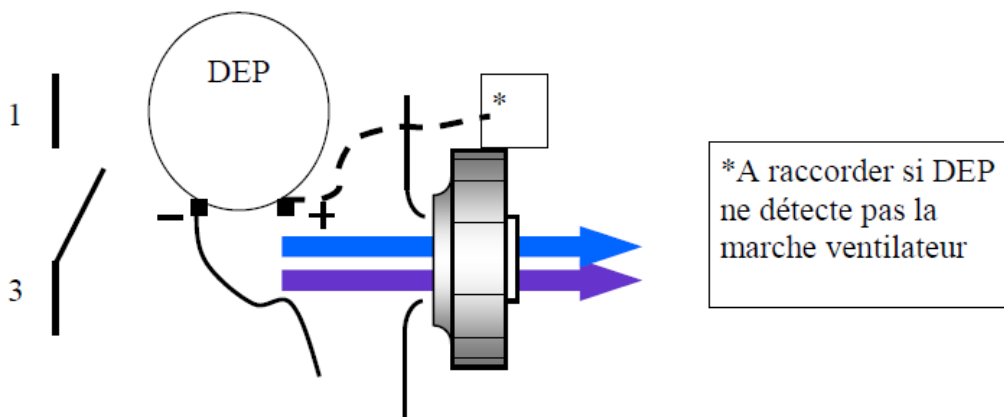

IV.8. Pressure transmitters wiring and connection LOBBY®/MAC2®/QUATTRO®

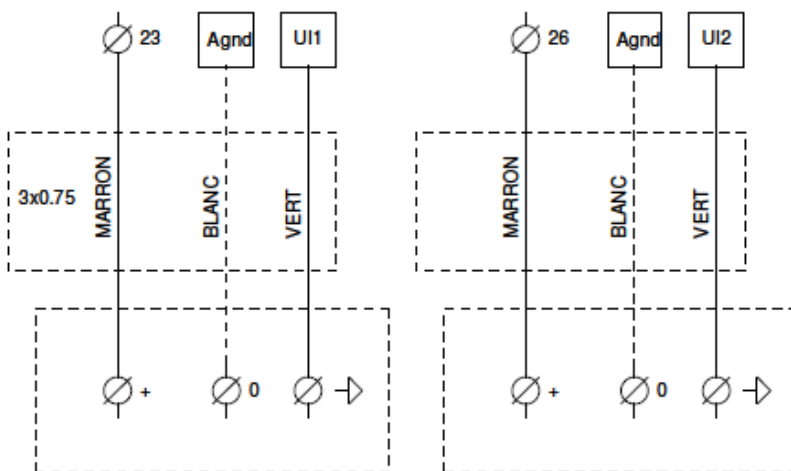

OPERATING AND COMMISSIONING INSTRUCTIONS

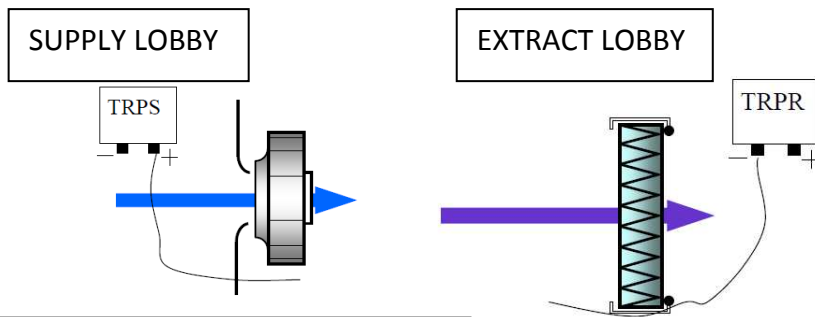

For version BC or CO, the pressure tube is installed after the coil

IV.9. Motors wiring

See chapter VIII.2 et VIII.3

IV.10. CO2 sensor wiring DIVA[®] QUATTRO[®]

CO2 transmitter is factory connected

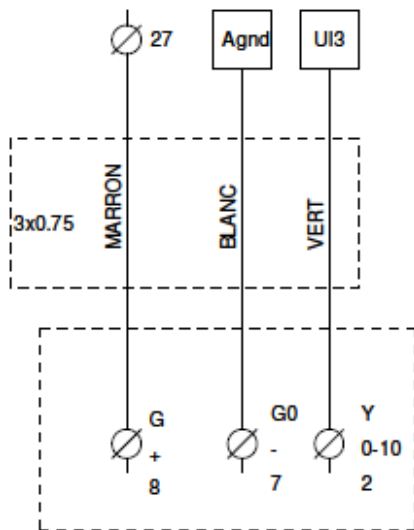

IV.11. Night Cooling

This function is used during summer to cool down buildings during nights with outside cool air. It decreases the cold needs during days. Night Cooling function runs only from 00:00 AM to 7:00 h AM. During Night Cooling, hot and cool outputs are locked on 0V. Exchanger runs only with fresh air. At the end of Night Cooling period heating is blocked to 0V during 60 minutes.

Start conditions: customizable in chapter V.5.b.2

- Outside temperatures are higher to 22°C during the day.
- Clocks are setted in LS or stopped during 00h00 and 07h00.
- Outside temperature is lower than 18°C during Night Cooling period
- Outside temperature is higher to 10°C during Night Cooling period
- Room temperature is higher to 18°C

During Night Cooling period fans are running 85% of their capacity. This speed is adjustable (see chapter V.5.b.2)

For LOBBY versions, a 24V output (to relay) is available between 22 and DO7 terminals to force the opening of damper's zone during Night Cooling period.

OPERATING AND COMMISSIONING INSTRUCTIONS

IV.12. Hot water coil integrated (PREMIUM BC) – changeover water coil (PREMIUM CO) or external cold or changeover coil

Pay attention to let the doors free of access (ducts, cables)

Hot water coil is mounted in the unit (PREMIUM BC and PREMIUM CO version), defrost Thermostat is connected. You have to cable the 3 ways valve. If a cold battery is used or changeover battery in duct is used, move the supply sensor after the battery.

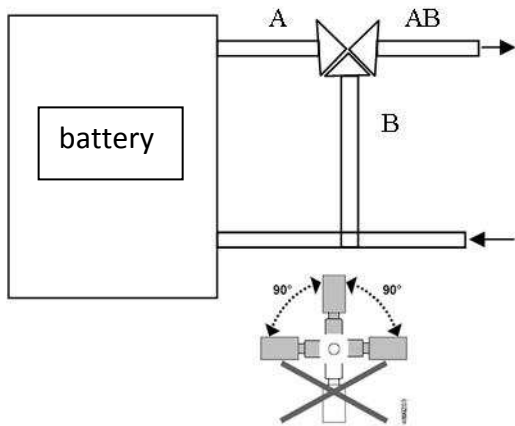

3 WAYS VALVE MUST BE CONNECTED WHEN POWER IS OFF

Connect the servomotor of the 3 ways valve as following instructions:

Hot Battery :

Terminal **15** on +24V (G) of the 3 ways valve actuator

Terminal **16** on 0V (G0) of the 3 ways valve actuator

Terminal **17** on 10V (Y) of the 3 ways valve actuator

Connect NC contact (C et 2) of the **THA** (Deicing Thermostat) on **5** and **6**.

Possibility to connect the circulator on the **DO3** terminal of the regulator and the terminal block **18**.

(Note: 24V output to relay)

Cold Battery : Install siphon on the drain evacuation

Terminal **28** on +24V (G) of the 3 ways valve actuator

Terminal **29** on 0V (G0) of the 3 ways valve actuator

Terminal **30** on 10V (Y) of the 3 ways valve actuator

Connect NC contact (C and 2) of **THA** (Deicing Thermostat) on **5** and **6**

Possibility to connect the circulator on the **DO4** terminals of the regulator and the terminal block number **19**.

(Note: 24V output to relay)

Batterie changeover : Install siphon on the drain evacuation

The changeover thermostat must be connected to the water inlet before Bypass.

You must cable 3 ways valve to the changeover thermostat.

Connect them following the instructions below :

Red wire to the changeover thermostat (CO) on 10V (Y) of the valve

Terminal **15** on +24V (G) of the 3 ways valve actuator

Terminal **16** on the 0V (G0) of the 3 ways valve actuator

Terminal **17** connected to the brown wire of the changeover thermostat (Heat signal)

Terminal **30** connected to the black wire of the changeover thermostat (Cold signal)

Connect the NC contact (C and 2) of **THA** (Deicing Thermostat) on **5** and **6**

Possibility to connect the circulator on the **DO3** terminal of the regulator and the terminal block **18** (heat demand) and on the **DO4** terminals of the regulator and the terminal block number **19** (cold demand). (Note: 24V output to relay)

ATTENTION In this case use a relay for each exit and cable in parallel on the ON/OFF of the circulator.

OPERATING AND COMMISSIONING INSTRUCTIONS

IV.13. DX battery (cold or reversible)

DX battery is mounted in the unit (version PREMIUM CO) **For units equipped with direct expansion battery, additional module is equipped with a drain pan. Plan to make a duct of the condensates with a siphon.**

At your disposal :

- 24 V output when unit is on cold or heating needs.
- 0-10V hot output and a 0-10V cold output.

Heating needs :

- 24V output: to connect to **DO3 terminals of the controller and 18 of the terminal block**. It allows the start to drive the direct expansion battery module (Attention 24V 2A Max to relay)
- 0-10V output: to connect to **15 and 16 terminals(15=0V et 16 =0/10V)**

Cold needs:

- 24V output: to connect to **DO4 terminals of the controller and 19 of the terminal block**. It allows the start to drive the direct expansion battery module (Attention 24V 2A Max to relay)
- 0-10V output: to connect to **29 and 30 terminals (29=0V et 30 =0/10V)**

ATTENTION: In case of a 24V output is used, make a relay between each output and cable them in parallel on the M/A of the direct expansion module.

ATTENTION: The command 24V et 0-10V start do not manage any safety ... of the direct expansion module.

IV.14. Electrical battery

Heating Electric batteries are single phased for FREETIME 500 à 1500 – HEXAMOTION 05-15 and three-phased for FREETIME 2000 à 3500 – HEXAMOTION 20-80.

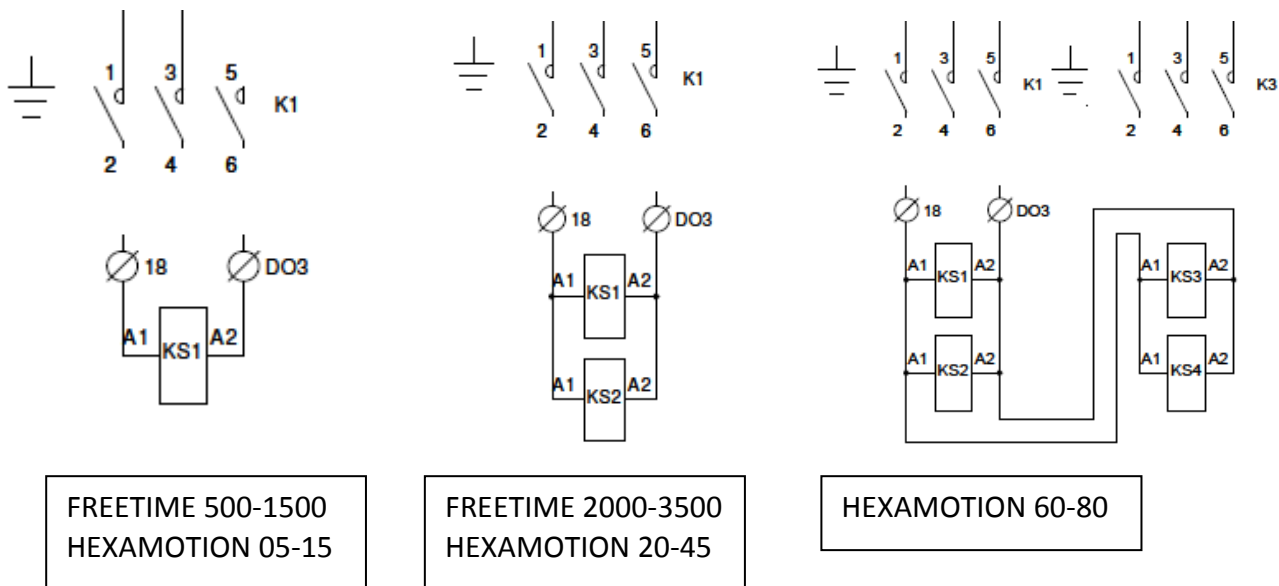

IV.15. Fire function

See configuration chapter V.8

There are 2 ways to drive the fire function:

- Emergency Fireman stop: cable between 1 and 2 terminals (NC free voltage contact). Total stop of the central control. (no display available)
- Fire alarm: this function controls exhaust and return fans with 5 modes available in the parameters of the regulation (the function can be activated on site). “fire alarm” will be on the display.
 1. « stop » : complete stop of the unit

OPERATING AND COMMISSIONING INSTRUCTIONS

2. «**continuous work**» : Start of the unit in HS, fire function will have priority on all the other alarms.
3. «**Normal work**» : keeps the unit running with parameters activated on site (Stop/LS/HS)
4. «**Supply fan only**» : start or keeps in HS the supply fan (extract stopped)
5. «**Extract fan only**» : starts or keeps in HS the extract fan (supply stopped)

Digital input « external stop » is priority on fire function.



This function is not adapted anymore to the French market and will be in all cases validated by the control office.

Digital input fire alarm will be connected between **DI8 terminal of the controller and 13 of the terminal block (free voltage contact required)**

)

IV.16. Dehumidification function

See parameters in chapter V.8

It is possible to associate the unit to a COMBIBOX CONCEPT® module equipped with a cold battery (water or cold direct expansion module only) followed by a hot battery (water or electric or hot direct expansion module DX heat). In this case controller will manage automatically the heating or cold inputs for the dehumidification and will keep an ideal functioning temperature. During cold needs period, the temperature management will have priority on dehumidification.



Function non available in DIVA mode

Connect batteries as indicated in chapters IV.12, IV.14

Install the humidity duct sensor in supply or extract air, following the humidity control mode.

Connect the humidity sensor as following instructions :

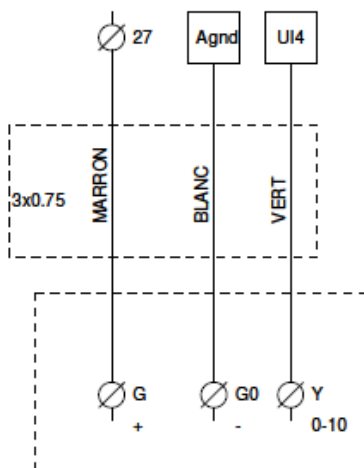

OPERATING AND COMMISSIONING INSTRUCTIONS

IV.17. MODBUS / WEB / BACNET wiring

(see parameters in chapters V.8)

MODBUS RS485 and BACNET MSTP: Use armoured cable 2 crossed pairs wire type BELDEN 8723 or similar to connect BMS to controller (to connect to port 1 (BANE) / connect armour to N and don't connect E)

WEB / MODBUS TCP/IP et BACNET IP: to connect to TCP/IP port

BMS : en standard

- MODBUS / RS485 ou TCP/IP
- WEB / TCP/IP
- BACNET / TCP/IP ou MSTP
- EXO / TCP/IP

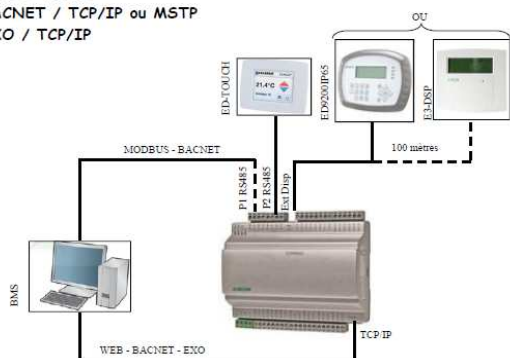

IV.18. Repeater wiring

see parameters in chapter V.8

You need to use a repeater in case of you want to connect:

- More than one unit on the same display (maximum 6)
- A remote control at a distance higher than 100m

In this case you can move to 1 kilometer the remote control. Use 2 crossed wire type BELDEN 8723 or similar between repeater and controller. Supply repeater in 230V single mono phase.

Connect on port 1 the wires as following instructions :

- **B** of repetitor on B terminal of the regulation board (armour wire as in drawing under)
- **A** of repetitor on A terminal of regulation board (armour wire as in drawing under)
- **N** of repetitor on N terminal of regulation board (armour wire as in drawing under)

Plan a 230V single phase power supply on the repetitor.

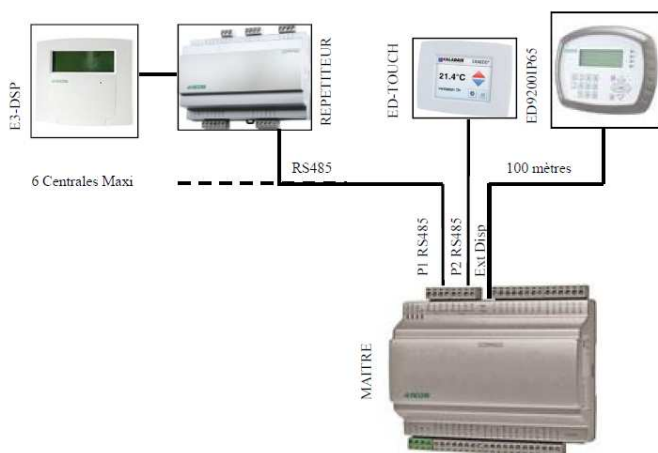

OPERATING AND COMMISSIONING INSTRUCTIONS

IV.19. LON

(see configuration in chapter V.8) Wired port 2 of master on port 1 of LON controller

BMS : LON

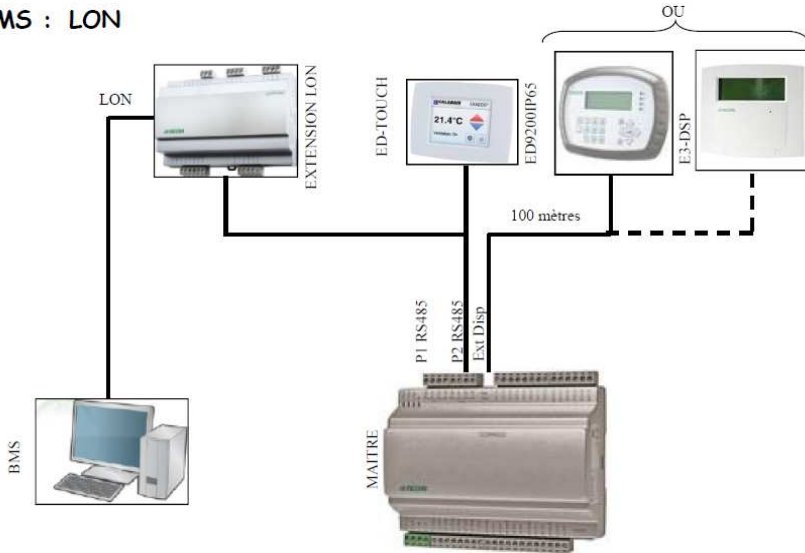

V. SETTINGS

V.1. Display

FREETIME® is delivered in standard with **ED-TOUCH** touch screen display. With the **ED-TOUCH**, you have access to emulator (see manual **ED-TOUCH**)

HEXAMOTION® is delivered in standard with **ED9200IP65** display

Once accessed to the emulator settings , you will have access to all function and screens below

- Directional arrows up, down left and right help to navigate in the menus.
- Up and Down buttons help to increase or decrease the values of a parameter when you have access to. Right and left buttons help to navigate inside the parameter.
- OK button help to enter the value and to confirm a choice. C button helps to cancel it.
- Alarm button (red) allows the access of the defaults list.
- Left arrow also helps to go out of the alarm menu and go back to the main menu
- Cursors indicate the possible movements and which arrows to press.

V.2. Exemple of setting

- Move the cursor to the required menu

In the required menu:

Hour : ex : **10:33**
Date : ex : **08/12/23** (year/month/day)
Day : ex : **Mardi**

press OK

Enter the password if necessary

- Enter the required value with arrows or with numerical keyboard
- Press OK to valid and go to next step.

When values are updated press the left arrow to come back to the welcome screen

OPERATING AND COMMISSIONING INSTRUCTIONS

V.3. Standard settings (operator menu)

Words in normal writing = viewing only / **Words in bold** = Modification is possible / **Outlined words in bold**= Modification is possible with password 3333 ... = non accessible or not used

ATTENTION : Do not modify parameters which are not in bold characters, in this case no after sales will be admitted

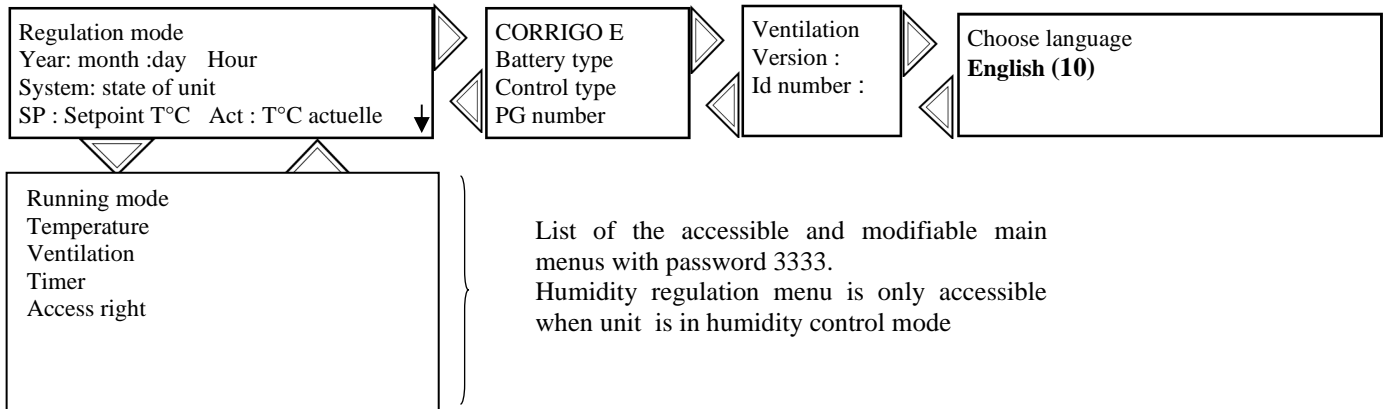

(10) Language setting (see chapter V.4.e)

OPERATING AND COMMISSIONING INSTRUCTIONS

V.3.a. Menu Mode de fonctionnement

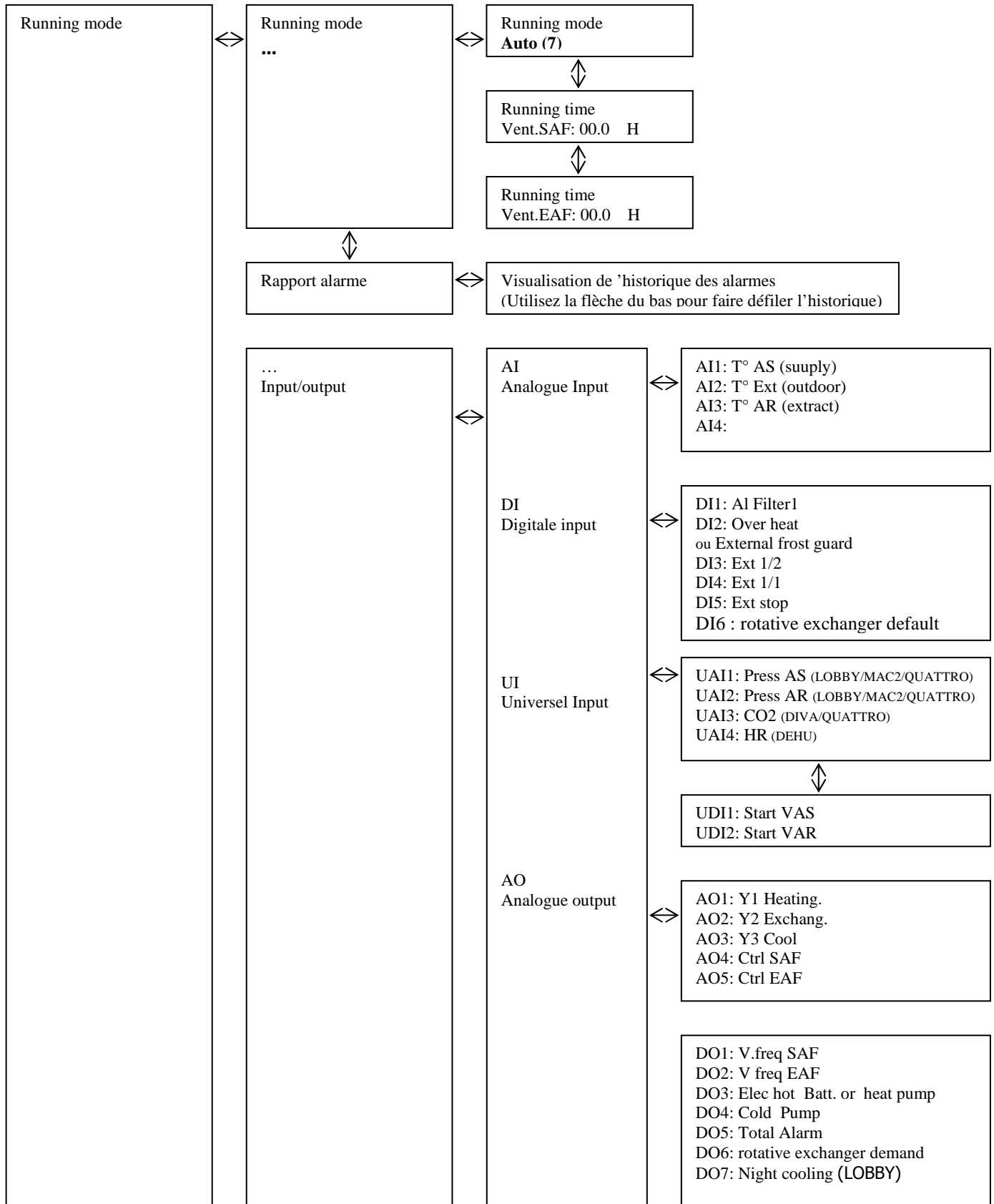

(7) **Unit Start/Stop (see chapter V.4.d)**

OPERATING AND COMMISSIONING INSTRUCTIONS

V.3.b. Temperature menu

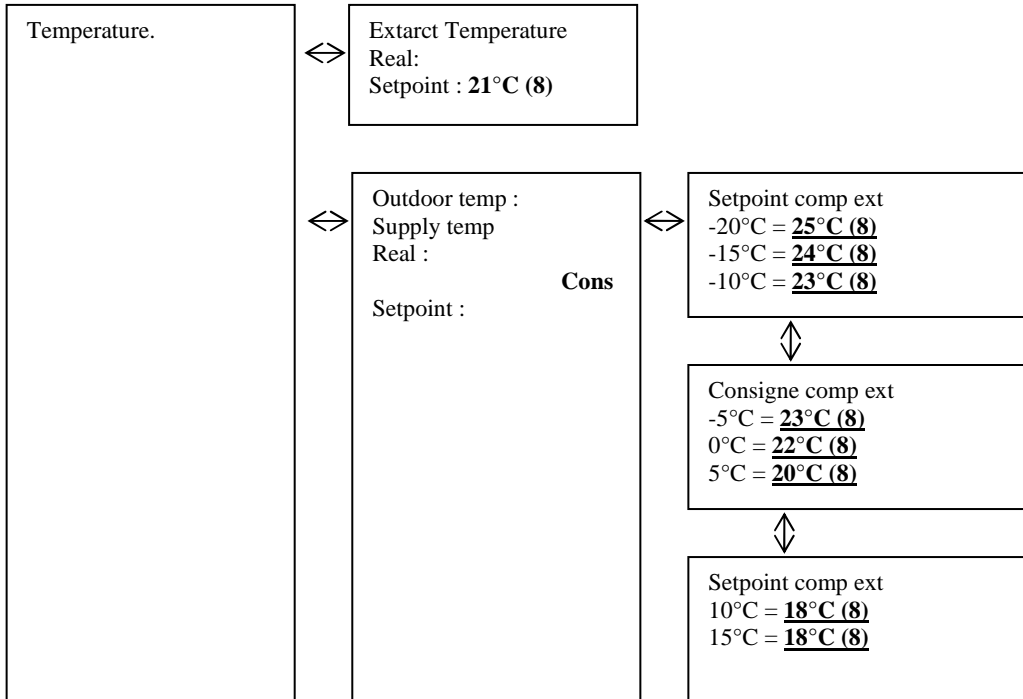

(8) Temperature setpoint setting (see chapter V.4.c)

V.3.c. Ventilation menu

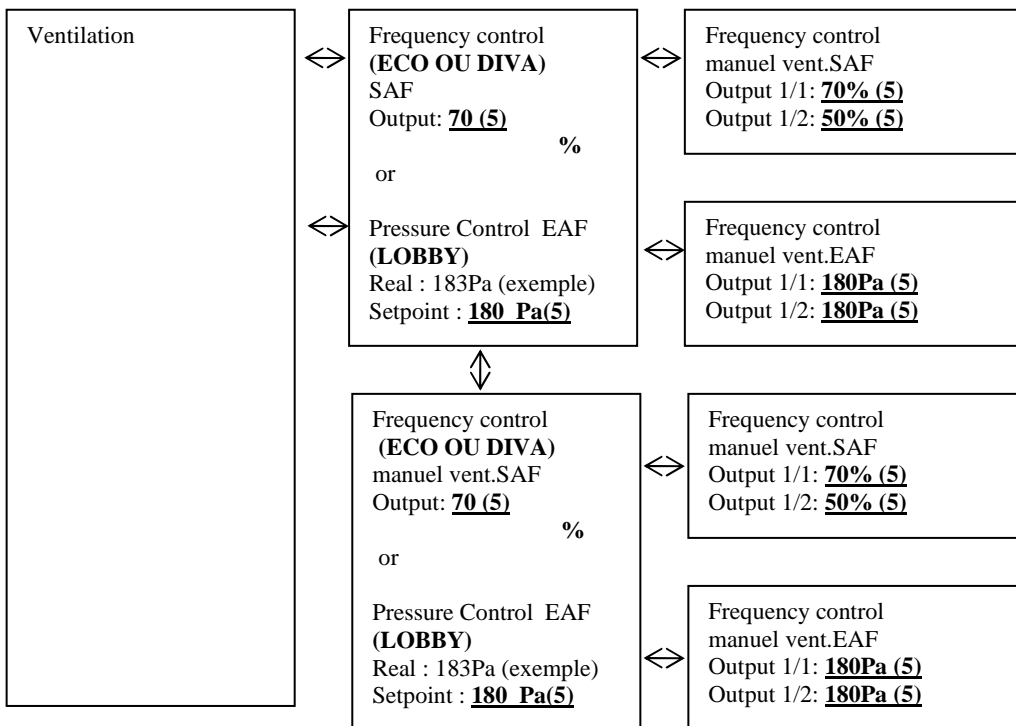

(5) Speeds, pressures, airflows (see chapter V.4.b)

OPERATING AND COMMISSIONING INSTRUCTIONS

V.3.d. Timer menu

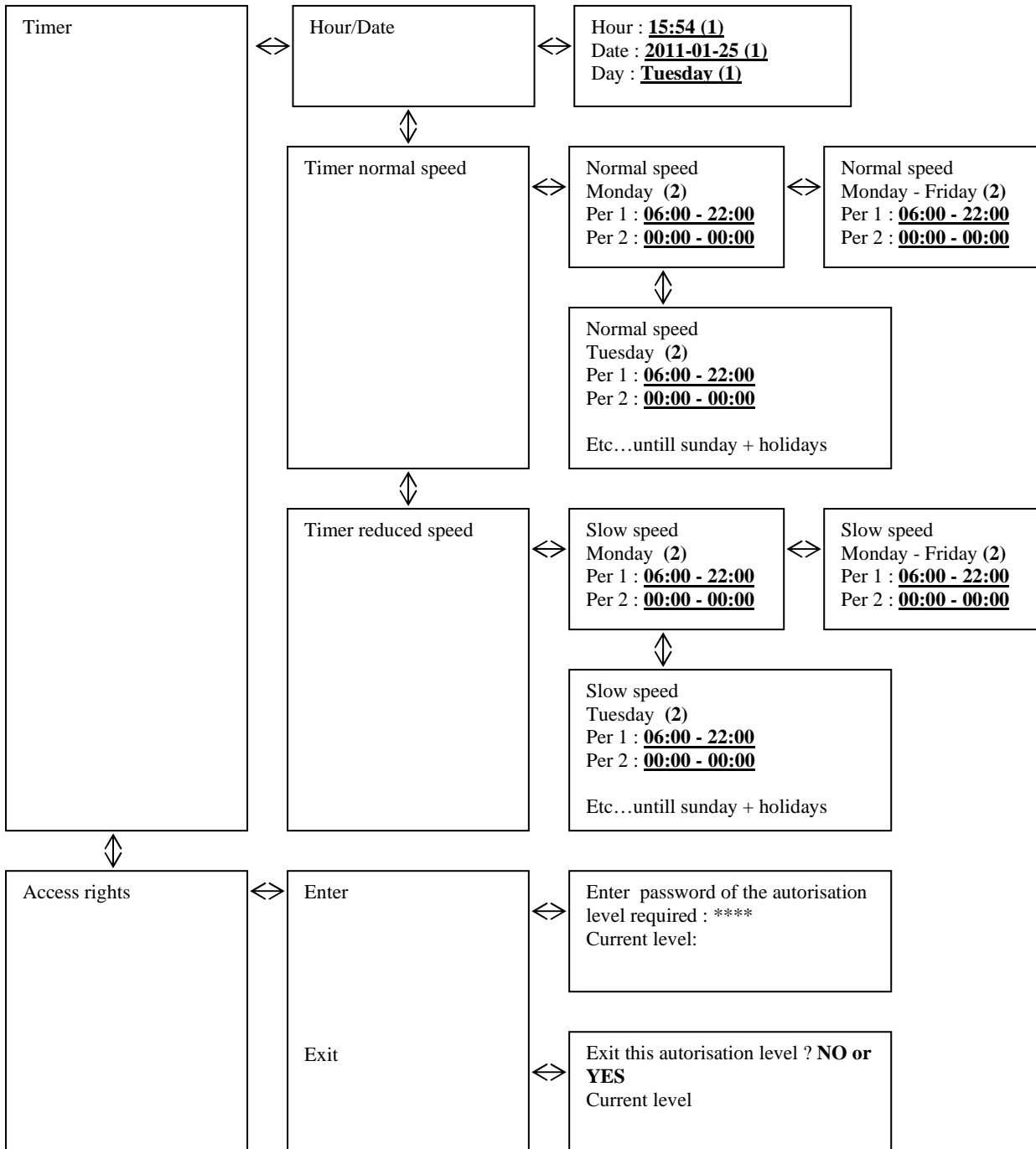

1. Hour and date setting (see chapter V.4.a)
2. HS program setting (see chapter V.4.a)
3. LS program setting (see chapter V.4.a)
4. Holidays period setting (see chapter V.4.a)

OPERATING AND COMMISSIONING INSTRUCTIONS

V.4. Operator parameters modification (password 3333 required)

V.4.a. Dates and hours clocks setting

V.4.a.1. Date and hour of the CORRIGO controller [(1) chapter V.3.d]

Access : Hour Date setting

Date and hour of the regulator are set by default in the CORRIGO controller. Summer/Winter time is automatically managed.

V.4.a.2. Hour programming of the functioning system [(2) (3) chapter V.3.d]

Access :

- **Timer normal speed** : Time settings / normal speed programm
- **Timer reduced speed** : Time settings / slow speed programm

System is set to work in normal speed (HS-1/1) **07:00 - 22:00** in slow speed (LS-1/2) **22:00 - 06:00** except **DIVA / LOBBY / QUATTRO** versions which work in slow speed (LS-1/2)

As indicated in arborescence you also have the possibility to modify Monday to Friday periods by pressing the right button when you are on the Monday screen

Nota : if slow speed (LS-1/2) and normal speed (HS-1/1) are activated in the same time window, unit works in high speed

Operation exceptions:



DIVA®/QUATTRO® : For CO2 regulation do not activate any normal speed time window (GV-1/1)

LOBBY: Only slow speed clock (LS-1/2) must be activated

NIGHT COOLING: Only works if unit is in slow speed (LS-1/1) between 00:00 and 07:00.AM (Example: If unit is in (LS-1/2) between 02:00 and 06:00 and in (HS-1/1) the rest of the time. Then NIGHT COOLING is allowed to work only from 02:00 to 06:00 AM)

V.4.a.3. Vacation time [(4) chapter V.3.d] (password 3333 required)

Access : Hour settings / holidays

System is set with no vacation time. If you need to reduce fonctionnement time during vacation time, set the functioning time window as indicated in chapter V.3.4), and set the vacation days.

V.4.b. Speed /pressure modification in LS and HS

V.4.b.1. STANDARD (ECO) / DIVA [(5) chapter V.3.c]

Access : ventilation Regul / Frequency control VAS 1/1 and 1/2 or frequency control VAR 1/1 et 1/2

You can modify the rotation speed of the unit in PV-1/2 (slow speed) and in HS-1/1 (normal speed) for each fan to set the airflows.

- To set the initial airflow (GV-1/1), force the system in normal speed with available terminals « Forced start HS » (bridge between 11 and 12 terminals).
- To set the initial airflow LS, force the system in slow speed with available terminals « Forced start LS » (bridge between 9 and 10 terminals).

V.4.b.2. LOBBY [(5) chapter V.3.c]

Access : ventilation Regul / Pressure control VAS 1/2 or Pressure control VAR 1/2

You can modify the constant pressure of the unit for each fan to set the airflows.

- To set the initial airflows LS, force the system in normal speed with available terminals « Forced start LS » » (bridge between 9 and 10 terminals).

V.4.b.3. MAC2®/QUATTRO® [(5) chapitre V.3.c]

Access : ventilation Regul / Airflow control VAS 1/1 and 1/2 or Airflow control VAR 1/1 and 1/2

You can modify the rotation speed of the unit in PV-1/2 (slow speed) and in HS-1/1 (normal speed) for each fan to set the airflows.

- To set the initial airflow (GV-1/1), force the system in normal speed with available terminals « Forced start HS » (bridge between 11 and 12 terminals).
- To set the initial airflow LS, force the system in slow speed with available terminals « Forced start LS » (bridge between 9 and 10 terminals).

OPERATING AND COMMISSIONING INSTRUCTIONS

V.4.c. Temperature setpoint modification

[(8) chapter V.3.b]

Access : temperature Regul

Regulation is based on the temperature control of :

- Supply with external compensation (set in standard). Supply temperature setpoint follows outside temperature in compliance with RT 2012 norm.
- Extracxt

V.4.d. Forced stop of the unit or forced start LS or HS on the remote control

[(7) chapter V.3.a]

Access : running Mode / running Mode

You can stop (7) (**stop**) unit with CORRIGO controller or do a forced start LS (7) (**manual speed 1/2**) or HS (7) (**manual speed 1/1**). In standard unit works automatically with clocks (7) (**Auto**)



If unit do not work in automatic mode an alarm will start. Manual speed 1/1 and manual speed 1/2 modes must be used only for the commissioning and repair. An other setting will lead to a failure of the unit.

V.4.e. Choice of language

[(10) chapter V.3]

Access: Starting screen / language choice

V.5. Intermediate settings (service level)

Type of regulation type setting, Night Cooling parameters and CO2 setpoint require an access to the Configuration menu. You need the access right to the « Service » level. Follow the instructions below.



Enter **2222** with directional arrows and validate with OK. Press left arrow twice to reach the access of the menus. In case of mistake press C button twice and start again.

OPERATING AND COMMISSIONING INSTRUCTIONS

V.5.a. Menu configuration en accès service

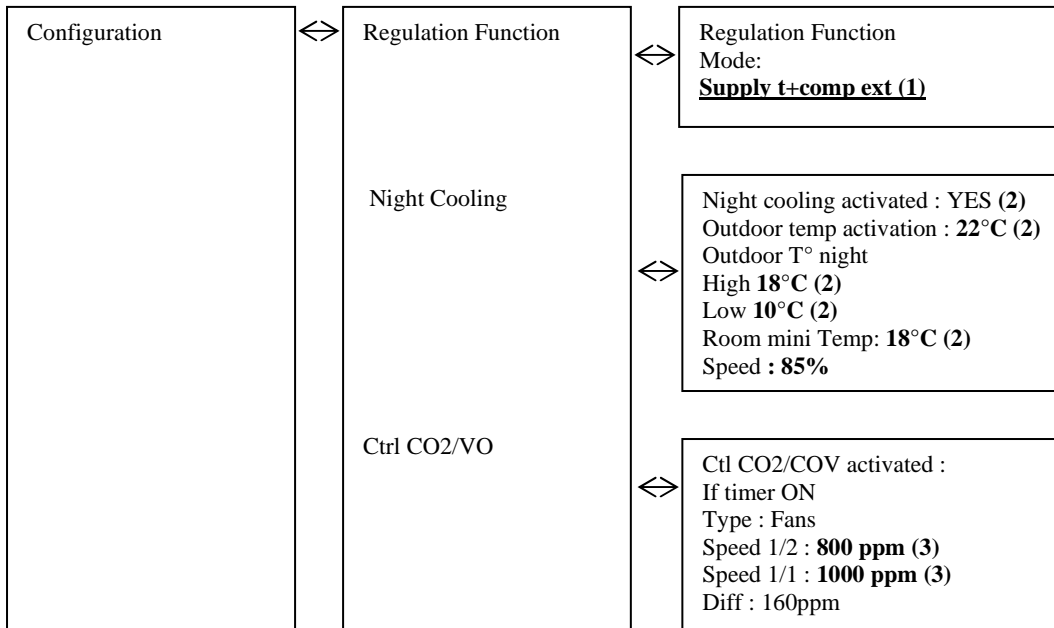

1. Regulation type choice (see chapter V.5.b.1)
2. Parameters modification Night Cooling (see chapter V.5.b.2)
3. CO2 set point modification (only in DIVA and QUATTRO) (see chapter V.5.b.3)

V.6. Modification of the services parameters (password 2222)

V.6.a. Regulation mode of the unit

[(1) chapter V.5.a]

Access : Configuration / Regulation function.

Regulation type is set by default in the CORRIGO controller in outside compensation exhaust. You can also select return control mode.

(ATTENTION, if you want to regulate following a room temperature, select the regulation mode« Ctrl extract » Any other mode will lead to the failure of the unit)

V.6.b. Overventilation parameters

[(2) chapter V.5.a]

Access : Configuration / Night cooling

Night cooling speed is set in standard in 85%. You can modify it. You can also change the temperature of Night Cooling activation (outside temperature day...) and deactivate it.

V.6.c. CO2 setpoint for DIVA / QUATTRO option

[(3) Chapter V.5.a]

Access: Configuration / Ctrl CO2/COV

CO2 setpoint is set in standard: LS = 800ppm HS = 1000ppm. Unit will increase its speed proportionally to reach its maximum speed when CO2 will be at 1000ppm.

OPERATING AND COMMISSIONING INSTRUCTIONS

V.7. Administrator settings

Activation of the **communication**, **dehumidification** and **fire function** requires an access to Configuration menu in system level. You have to get the access rights to « Admin » level. Follow the instructions below:



Enter **1111** with directionnal arrows and validate with OK button. Press left arrow twice to reach the menu. In case of mistake press C button twice and start again

V.7.a. Configuration menu with admin level access

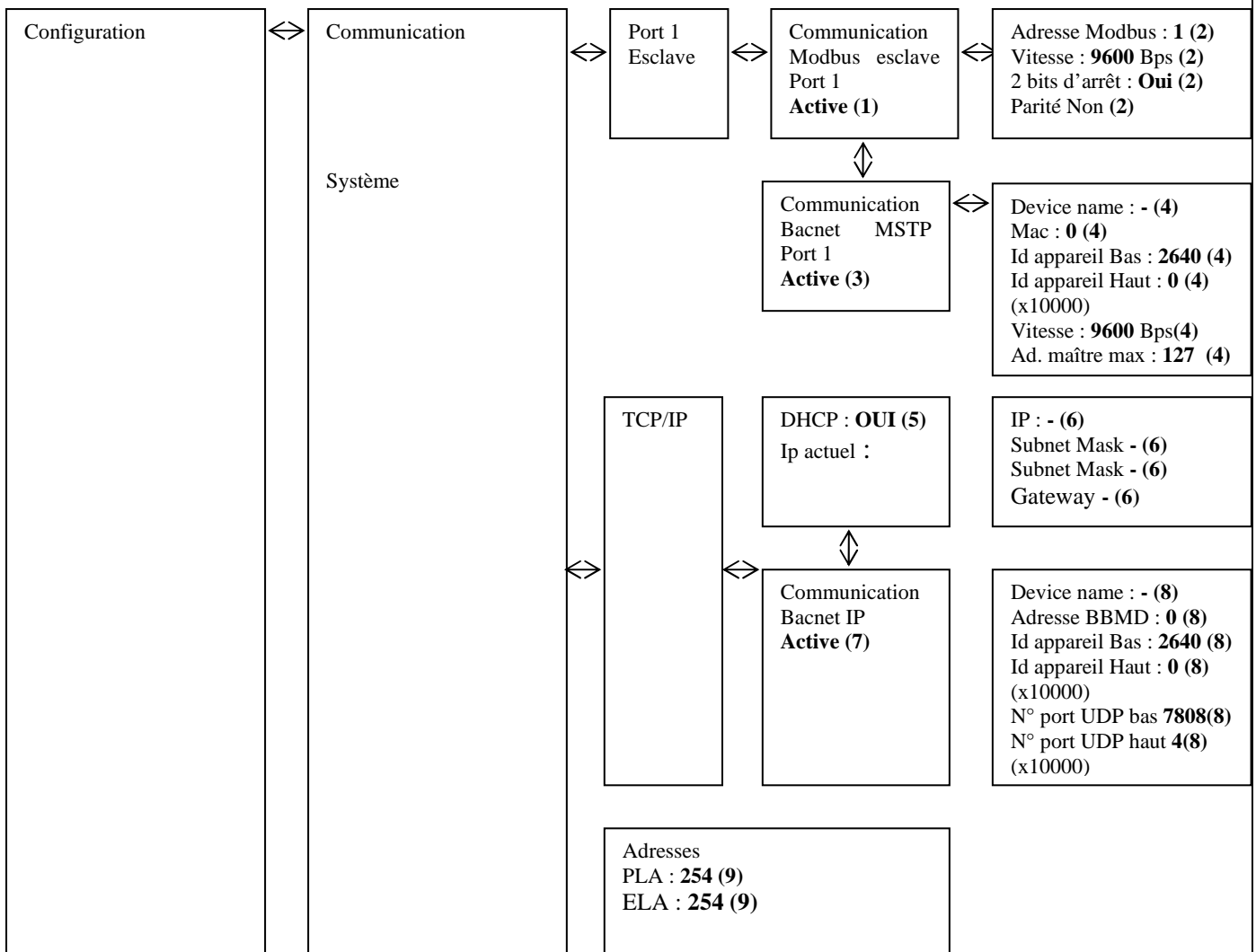

- 1 et 2 Activation MODBUS RS485 and settings (see chapter V.8)
- 3 et 4 Activation BACNET MSTP and settings (see chapter V.8)
- 5 et 6 Settings TCP/IP(see chapter V.8)
- 7 et 8 Activation du BACNET IP and settings (see chapter V.8)
- 9 Adressage Repetiteur (voir chapitre V.8)

OPERATING AND COMMISSIONING INSTRUCTIONS

V.8. Modification of the service parameters

V.8.a. MODBUS

You will find the simplified MODBUS at the end of the instructions and commissioning manual.

Access : Configuration / Communication

MODBUS TCP/IP is activate in standard in DHCP. Possibility to know DHCP adress or set IP fixe [(5)(6) chapter V.7],

Modbus Port = 502 / Device ID = 255

Le **MODBUS RS 485** must be activate [(1) chapitre V.7]. Possibility to set speed, parity, stop bits... [(2) chapter V.7].

Modbus Type

1 = Coil status register (Modus fonction 1, 5 et 15)

2 = Input status register (Modus fonction 2)

3 = Holding register (Modus fonction 3, 6 et 16)

4 = Input resister (Modus fonction 4)

Supported Modbus functions

Read Coils (1)

Read discrete input (2)

Read Holding registers (3)

Read Input registers (4)

Write single Coils (5)

Write single register (6)

Write multiple Coils (15)

Write multiple register (16)

EXOL Type

R = Real (-3.3E38 – 3.3E38)

I = Integer (-32768 – 32767)

X = Index (0 – 255)

L = Logic (0/1)

Transmission mode

Controller is set in RTU mode

A maximum of 47 registers can be read in one message

V.8.a.1. *Repetitors and EXO communication*

[(3) chapitre V.7]

Access : Configuration / System

An instruction and commissioning manual is delivered with repetitor. In the case of you have several CORRIGO connected to the same remote control (up to 6 CORRIGO), you have to modify the address PLA / ELA of each CORRIGO. In this case you will need a different address on each CORRIGO and enter them in the repetitor. Follow the instructions in the commissioning manual for the setting and use.

V.8.a.2. *WEB Communication*

You have the possibility to communicate via TCP/IP WEB in language. In this case the device is delivered with Web page and regulator set in DHCP.

Possibility to know DHCP adress or set IP fixe [(5)(6) chapter V.7], or via E-tool software <http://www.regin.se>

OPERATING AND COMMISSIONING INSTRUCTIONS

V.8.a.3. BACNET IP Communication with BASC type

You will find the simplified BACNET at the end of the instructions and commissioning manual.

Accès : Configuration / Communication

BACNET IP must be activate [(7) chapter V.7]. Possibility to know DHCP adress or set IP fixe [(5)(6) chapter V.7]. Possibility to set ID / N°port... [(8) chapter V.7].

BACNET MSTP must be activate [(3) chapter V.7]. Possibility to set speed, ID, adress... [(4) chapter V.7]. Speed = 9600 / MAC adress = 0 / Device ID = 2640 / Max master = 127

BACnet Type

10XXX = Read and write Binary

20XXX = Read binary

30XXX = Read and write analogue

40XXX = Read analogue

30XXX = Read and write multistate

40XXX = Read multistate

(XXX = MODBUS Adress)

AV = Analogue Value

BV = Binary Value

MSV = Multistate value

BMMD Adress : The BBMD address is used for discovering devices taht are attached to different BACnet/IP subnets and separates by an IP router. The address is entered as host:host can be the host's name if DNS ins configures. If DNS is not configured, the host address should be entered in the format xxx.xxx.xxx.xxx follwed by the port number (default settings 47808)

MAC : The MAC address of the device. This need to be unique only to the subnet.

Device ID : The ID of a device, used to identify it on the BACnet network. This number cannot be duplicated anywhere on the BACnet network and must therefore be unique. To set an ID value of 34600, the low number would be set to 4600 and the high number to 3

For more information see CORRIGO Pics via <http://www.regin.se>

V.8.a.4. Communication LON (si CORRIGO avec option LON)

Set the LON function as below:

In Configuration menu/ Communication / Fonction port 2 = Activate the Port 2 function in extension unit.

Go on the right and activate extension unit. 1 en CORRIGO E28 LON

Button for the PIN service is at the back of the regulator.

Communication table is on <http://www.regincontrols.com>

V.8.a.5. Fire function activation

Setting of the Paramétrage de l'entrée

Access : Configuration / Input Output / DI / DI8

Déclarer l'input DI8 en « Al fire » « NO »

Paramétrage de la fonction

Access : Configuration / Fire function

Choose the required mode when activating the fire function

« Stop » : Complete stop of the unit

«Continuous operation »: Start or keeping of the unit in HS. Fire function will have priority on all others alarms.

«Normal operation»: keeps the unit in the same parameters chosen on site (stop/LS/HS)

« Exhaust fan only »: Start or keep in HS the exhaust fan (return is stopped)

« Return fan only »: Start or keeps in HS the return fan (exhaust stopped)

OPERATING AND COMMISSIONING INSTRUCTIONS

Alarm setting

Access: Configuration / alarm configuration

Enter alarm number « 10 » go on the right and enter in priority « C alarm C » « Active »

V.8.a.6. Activation of the function dehumidification

Input settings

Access : Configuration / Input Output / UI / UI4

Declare UI4 input in « Ambiance Humidity »

Function setting

Access: Configuration / Ctrl Humidity

Choose « Dehumidification »

Setpoint setting

Access: Humidity Regul

Enter the required setpoint

VI. REPAIR

VI.1. Different types of defaults

A specific screen appear if you have an alarm (see ED-TOUCH manual). Celui -ci sera de classe A, ou C (voir détail ci-dessous)
Type of default:

C : Default do not stop the ventilation system and automatically disappears when a solution is found.

To solve a default press the alarm button (red), « delete » then « enter » the default with directional arrows and press OK button Attention : do not « block »

Description	Cause
CORRIGO screen do not light up	<ul style="list-style-type: none"> - Unit is not powered correctly (LED P/B of CORRIGO switched off) - To light up the screen, press a button (backlit). - Command fuse is disused
Fans do not start	<ul style="list-style-type: none"> - Clocks are on 0 - No external start order - External stop - Active alarm
Remote control do not run or gives wrong values	<ul style="list-style-type: none"> Remote control further than 100m Repetitor is not connected correctly

VI.2. List of alarms

n°	View	Description	Type	Tempo	Cause
1	Malfunction supply air fan	(UDI2 must be closed « Fer »if fan runs) Or UAI2 must be higher than 30Pa if fan runs)	A	30s (120s for LOBBY)	<ol style="list-style-type: none"> 1. Pressure switch is wrongly connected (pressure switch must be set in 30Pa). 2. Pressure on the transmittor is lower to 30Pa. (LOBBY®) (contact us) 3. Motor is disused 4. Thermic protection motor is activated 5. Contrôler le raccordement des tubes crystal (chapitre IV.8 et IV.9 6. Présence d'eau dans le tube crystal 7. 0-10V motor is inverted

OPERATING AND COMMISSIONING INSTRUCTIONS

2	Malfunction extract air fan	(UDI3 must be closed « Fer » if fan runs) Or UAI3 must be higher than 30Pa if fan runs)	A	30s (120s for LOBBY)	<ol style="list-style-type: none"> 1. Pressure switch is wrongly connected (pressure switch must be set in 30Pa). 2. Pressure on the transmitter is lower to 30Pa. (LOBBY®) (contact us) 3. Motor is disused 4. Thermic protection motor is activated 5. Control the connection of the crystal tubes (chapter IV.8 and IV.9) 6. Water in the crystal tubes 7. 0-10V motor is inverted
6	Filter guard 1	DI1 must be open « Ouv » if there is no default	C	5s	<ol style="list-style-type: none"> 1. Filters are dirty 2. Filters pressure switches are wrongly connected (Pressure switches must be set on 150 Pa for G4 200Pa for F7). 8. Control the connection of the crystal tubes (chapter IV.8)
8	External frost guard	Ext DI3 must be closed « Fer » if there is not default	C	120s	<ol style="list-style-type: none"> 1. THA thermostat is not set on 5°C 2. THA thermostat s disused 3. Circulating pump is disused 4. 3 ways valve 3 is wrongly connected, hydraulically or is disused
15	High supply air temp	Ext AI1 is mounted higher than 50°C	A	30s	<ol style="list-style-type: none"> 1. Exhaust temperature is higher than 50°C 2. Temperature setting is too high 3. Exhaust fan is stopped (vent AS Default) when hot battery is in full capacity.
23	Electric heating is overheated	Ext DI3 must be closed « Fer » if there is no default	A	5s	<ol style="list-style-type: none"> 1. Safety thermostat THS is activated. To reset THS, push on the rearmament on the electric battery 2. Power cut 3. Exhaust fan is stopped (vent AS Default) when electric battery is in full capacity
27	Sensor error outdoor temp	Control the value Ext AI2	A	5s	Outside temperature sensor SEG is disused .Outside temperature sensor SEG is wrongly connected (see chapter IV.3)
29	Rotation sentinel exchanger	Control the value DI6	C	300s	The belt of the exchanger is brocken
31	Supply air fan control error	Difference higher than 50Pa between exhaust setpoint and pressure on Ext UAI1	C	30min	The network of blowing do not correspond to the fan or to the setpoint. Filter is dirty
32	Extract air fan control error	Difference higher than 50Pa between exhaust setpoint and pressure on Ext UAI2	C	30min	Return network do not correspond to the fan or to the setpoint. Filter is dirty
35	Manual	Runs in manual mode	C	5s	Default à titre indicatif (le centrale est passée à l'arrêt en PV ou en GV directement sur l'afficheur (voir (7) chapitre V.3.a)
36 à 44	... in Manual mode	Functions are modified in manual mode	C	5s	In the Auto Manual menu everything must be in Auto.

OPERATING AND COMMISSIONING INSTRUCTIONS

48	Internal battery error	Error battery intern	A	5s	Intern battery of the CORRIGO is disused Change the battery quickly in order to not loose programm. See chapter VII.2
49	Sensor error supply air temp	Control the Value on Ext AI1	A	5s	Outside temperature sensor SSG is disused Outside temperature sensor SSG is wrongly connected (see chapter V.3.a)
50	Sensor error extract air temp	Contrôler la valeur sur Ext AI3	A	5s	Outside temperature sensor SRG is disused Outside temperature sensor SRG is wrongly connected (see chapter V.3.a)
55	Sensor error pressure VAS	Control the value on Ext UAI1	A	5s	0-10V signal is inverted Pressure transmitter on fresh air is in short-circuit
56	Sensor error extract VAR	Control the value on Ext UAI2	A	5s	0-10V signal is inverted Pressure transmitter on intake air is short circuited
59	CO2 sensor error	Control the Value on Ext AI4	A	5s	0-10V signal is inverted CO2 transmitter is in short-circuit
85	... in manual mode	Functions are modified in manual mode	A	5s	In Manuel Auto menu everything must be in Auto.
86	Time for service	Regular visit	C	5s	See chapter VI.3
87	... in manual mode	Functions are modified in manual mode	C	5s	In Manuel Auto menu everything must be in Auto.

VI.3. Acknowledge the default « timer service »

These settings require an access to the setting menu. You need the access rights to “service” level. Follow the instructions below.



Enter the code **2222** with directional arrows then press the OK button. Press the left arrow twice to reach the menus. In case of mistake press C button twice and start again.

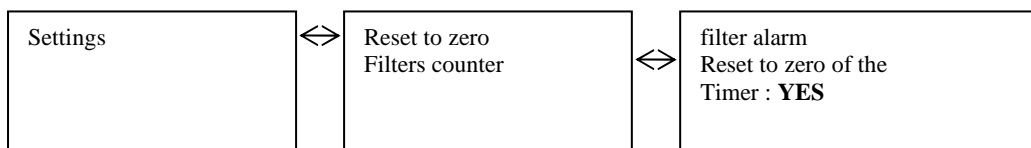

An alarm occurs every 6 months to remind the maintenance visit. Enter YES to reset the counter to zero

OPERATING AND COMMISSIONING INSTRUCTIONS

VII. MAINTENANCE

VII.1. Obligatory maintenance

Outside the unit

Check the ducts, flexible sleeves, anti-vibrating plots; replace them if necessary. Check that all elements connected to the unit do not give any vibration to the unit.

Unit and Regulation

Check connection every year

Filtration

Do not damage the filters

Classification	Max pressure drop	Efficiency of the filtration EUROVENT	Reference	Washing* (Water + light detergent)	Aspiration* Exhaust*
Gravimetric	150Pa	EU4	G4	Limited (1 to 4 times)	YES
Opacimetric	200Pa	EU7	F7	NO	

Componants	Periodicity of the cleaning			
	1 MONTH	3 MONTHS	6 MONTHS	12 MONTHS
<i>Filtration</i>	Blowing (for the G4filters)	Cleaning (for the G4filters)	Washing (for the G4filters)	Replacement Of the filters if needed

Rotative exchanger (12 month)

Check belt and change it if necessary

VII.2. Battery replacement

When low battery alarm starts and red LED is lighting, this indicates that the safety battery for the safeguard of the memory and clock is too low. Follow the instructions below to change them. A condenser keeps the safeguard and let the clock running for 10 minutes left after power cut. If the replacement of the battery takes less than 10 minutes, you will not have to reset the program and clock will work normally.

Replacement battery is a CR2032 type



Press the clips on each sides of the box with a little screwdriver to open the top of the box.

OPERATING AND COMMISSIONING INSTRUCTIONS

Location of the battery

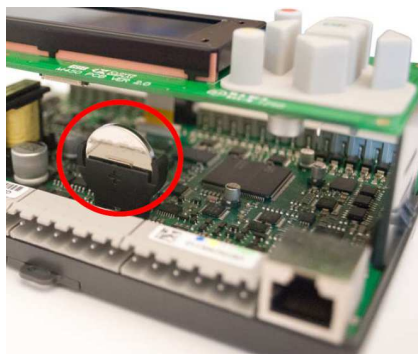

Take the battery and remove it softly .

Press firmly the new battery in the support. Note : Attention to the direction and polarity of the battery.

OPERATING AND COMMISSIONING INSTRUCTIONS

VIII. ANNEXES

VIII.1. Command diagram

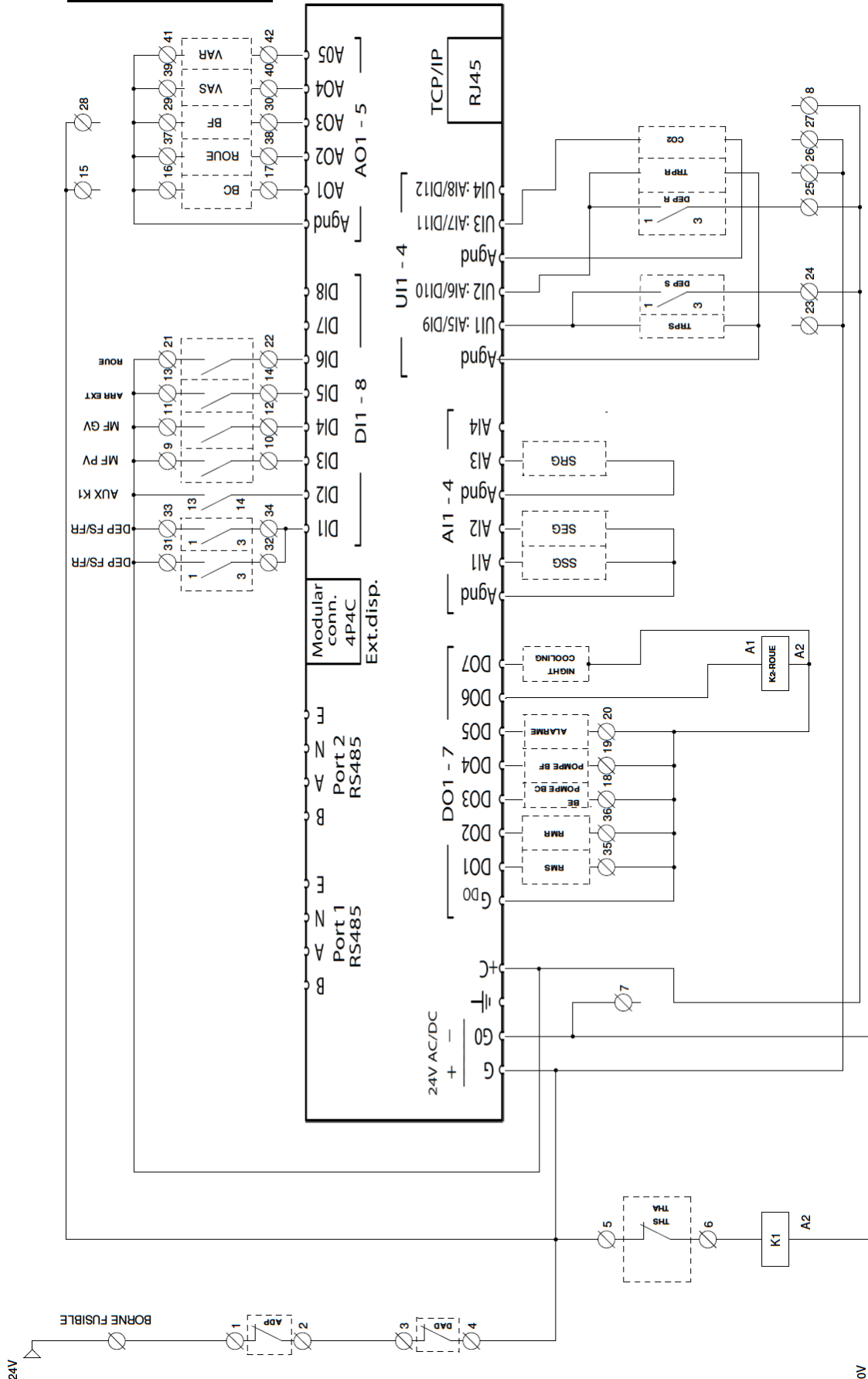

OPERATING AND COMMISSIONING INSTRUCTIONS

VIII.2. Motors diagrams FREETIME® 500-800 HEXAMOTION® 05-08

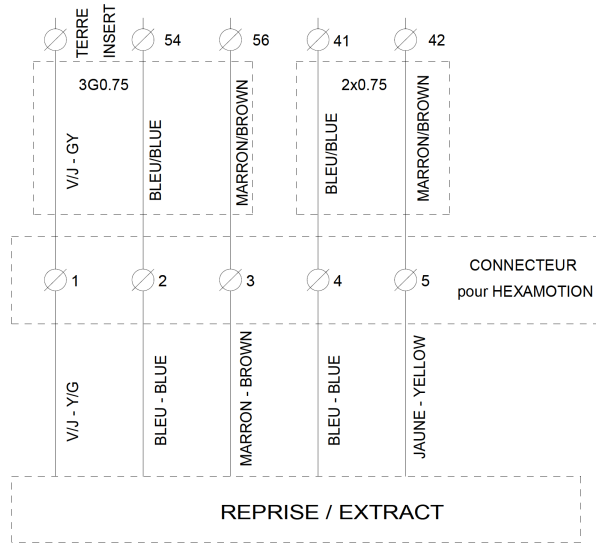
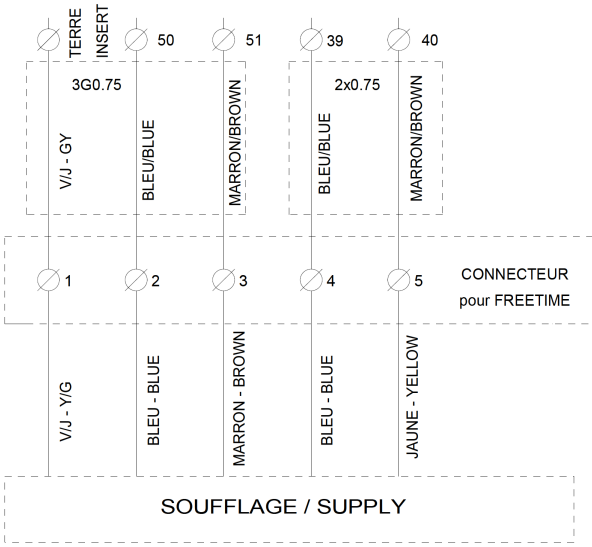

FIRST - PREMIUM

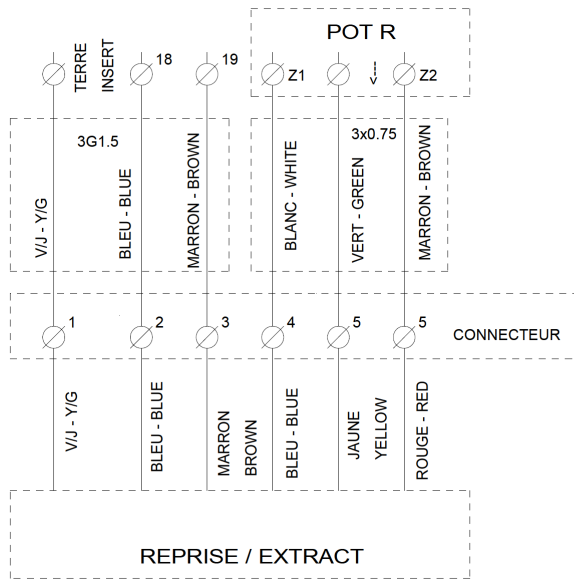
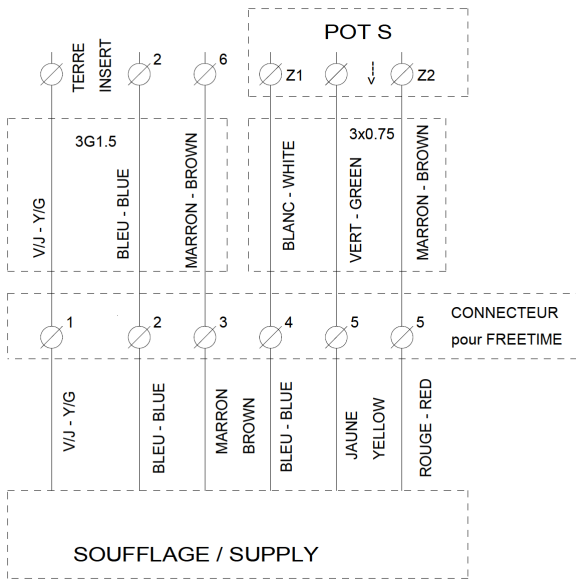

SEASON

OPERATING AND COMMISSIONING INSTRUCTIONS

VIII.3. Motors diagrams FREETIME® 1500 HEXAMOTION® 15

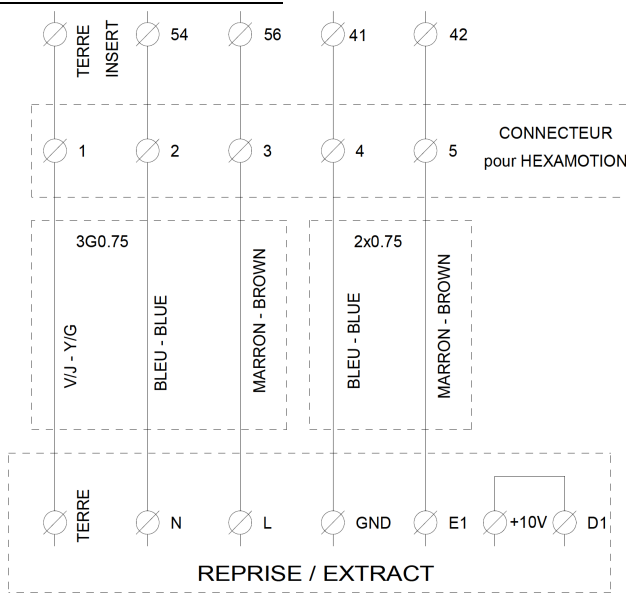
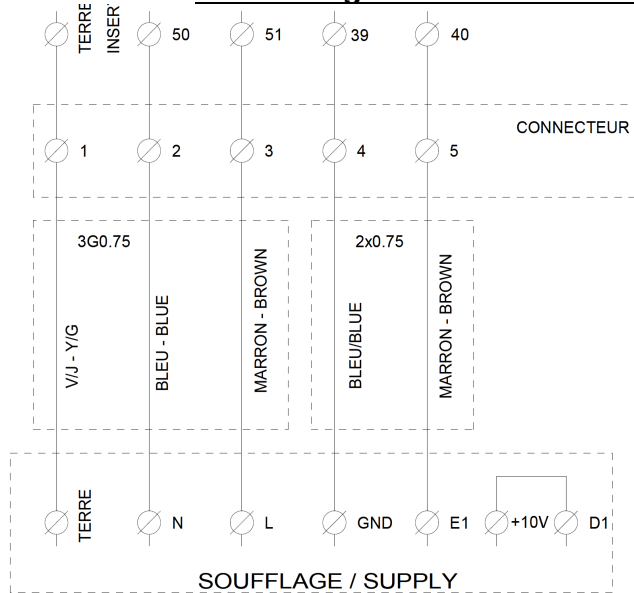

FIRST PREMIUM

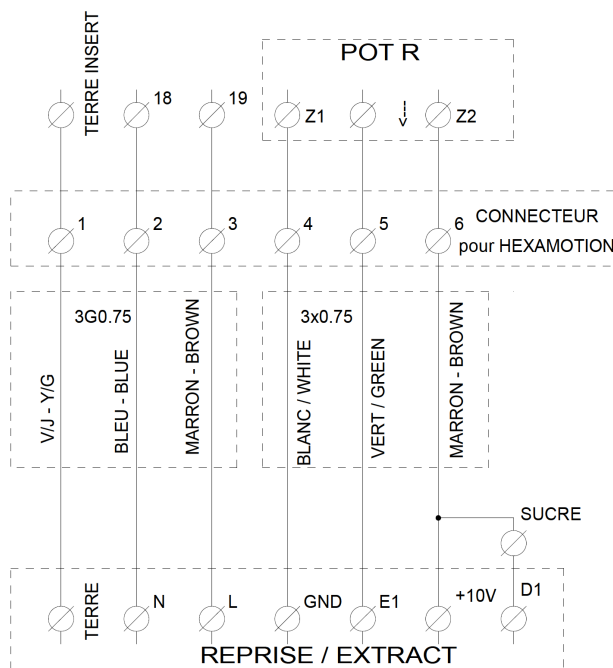
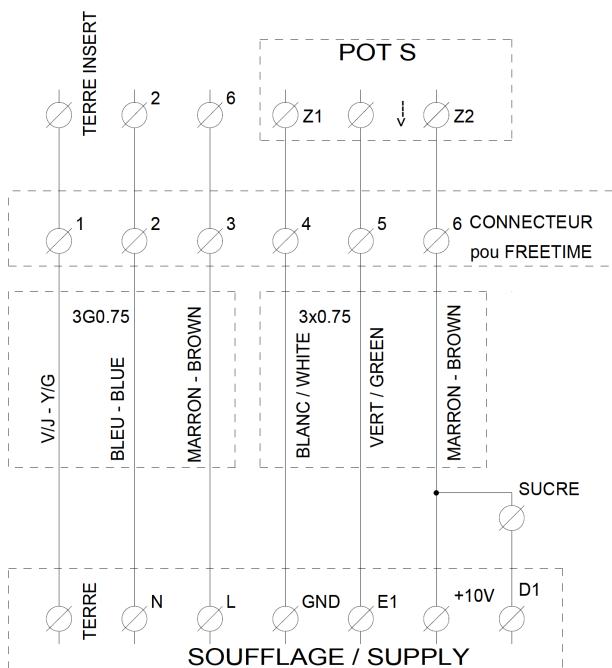

SEASON

OPERATING AND COMMISSIONING INSTRUCTIONS

VIII.4. Motors diagrams FREETIME® 2000 HEXAMOTION® 20

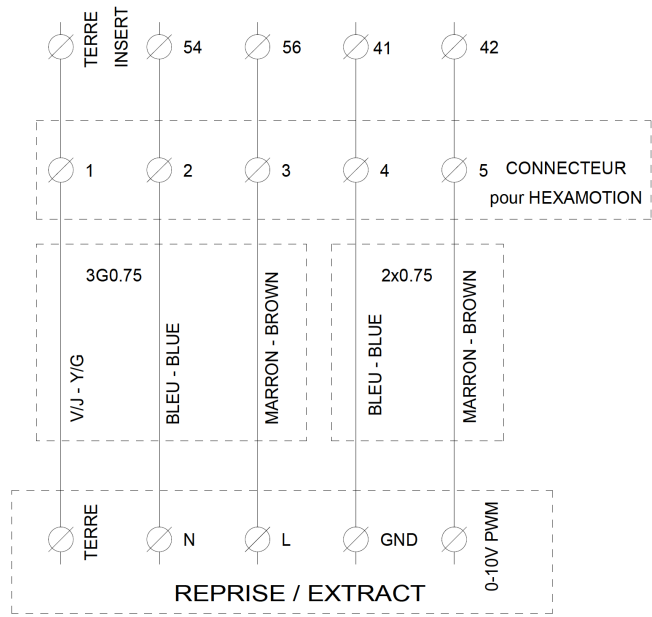
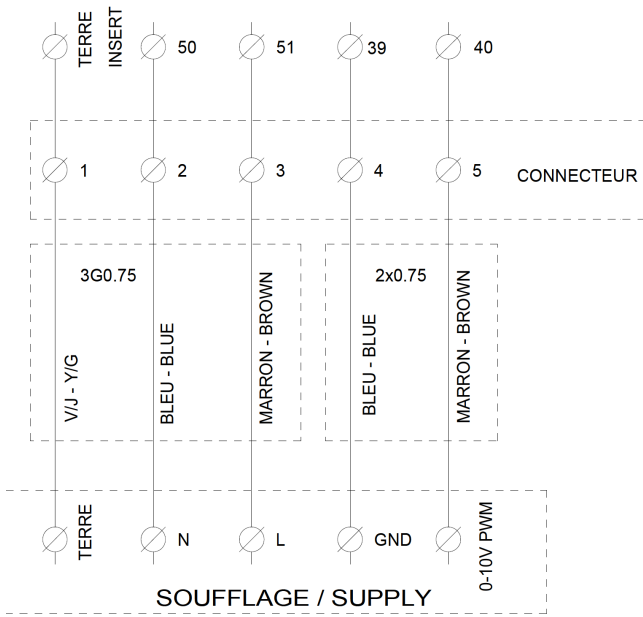

FIRST - PREMIUM

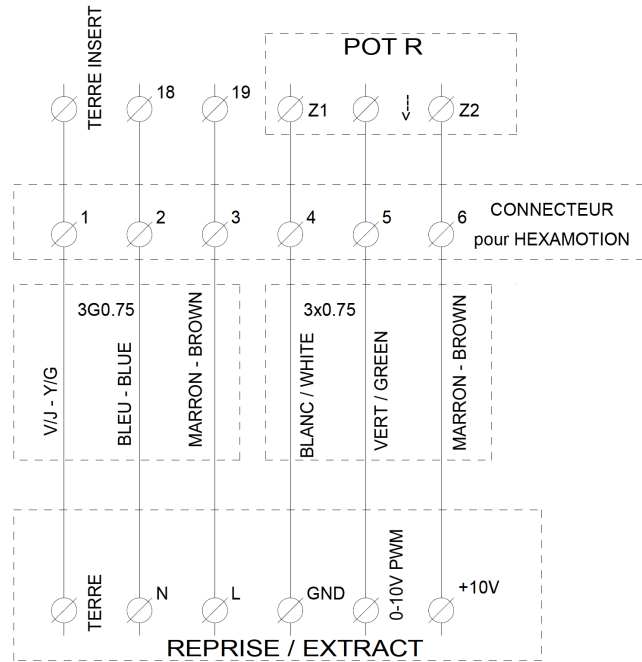
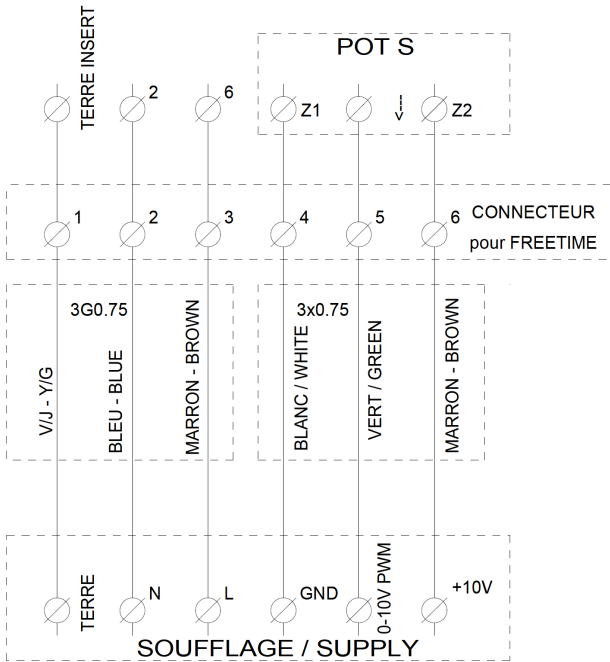

SEASON

OPERATING AND COMMISSIONING INSTRUCTIONS

VIII.5. Motors diagrams FREETIME® 2700-3500 HEXAMOTION® 27-80

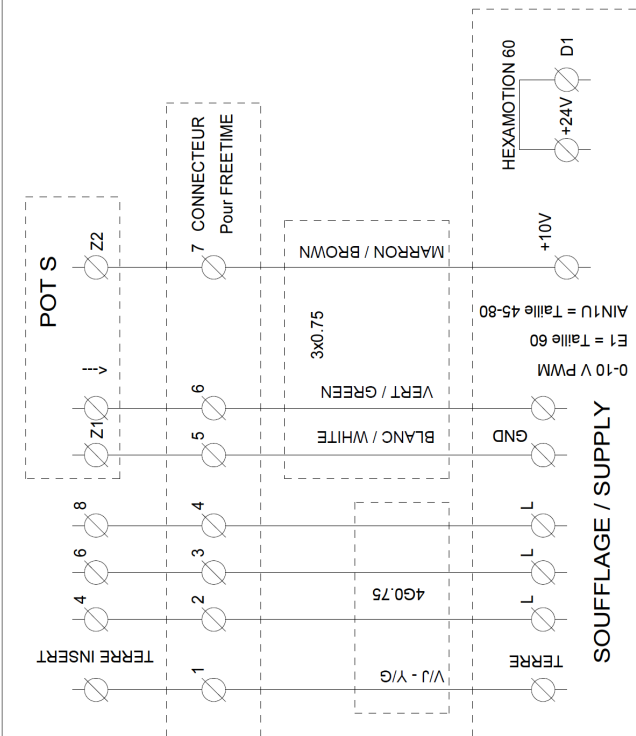
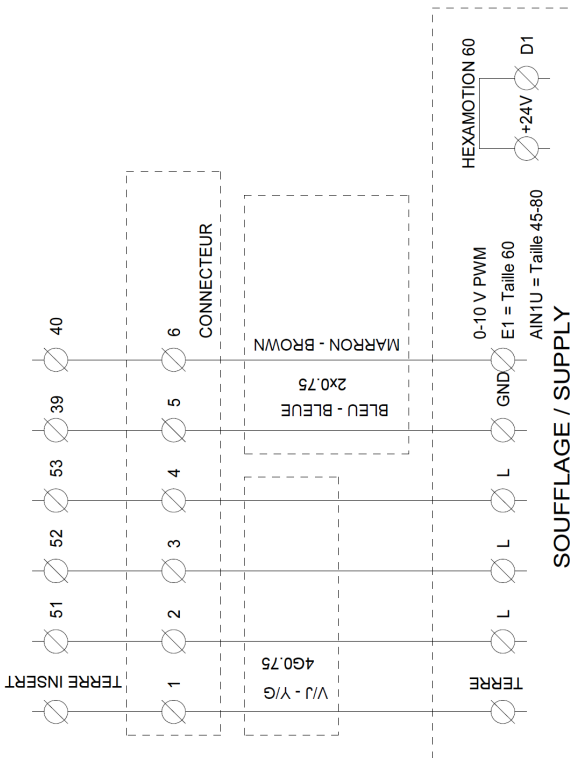
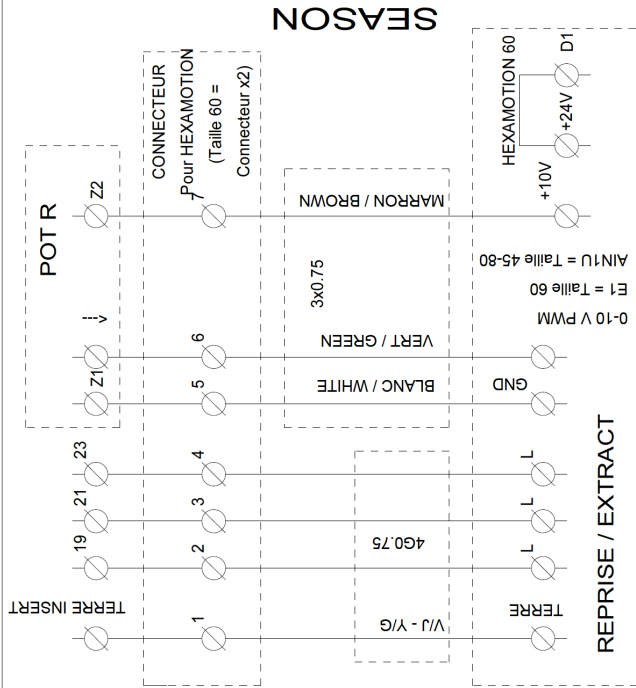
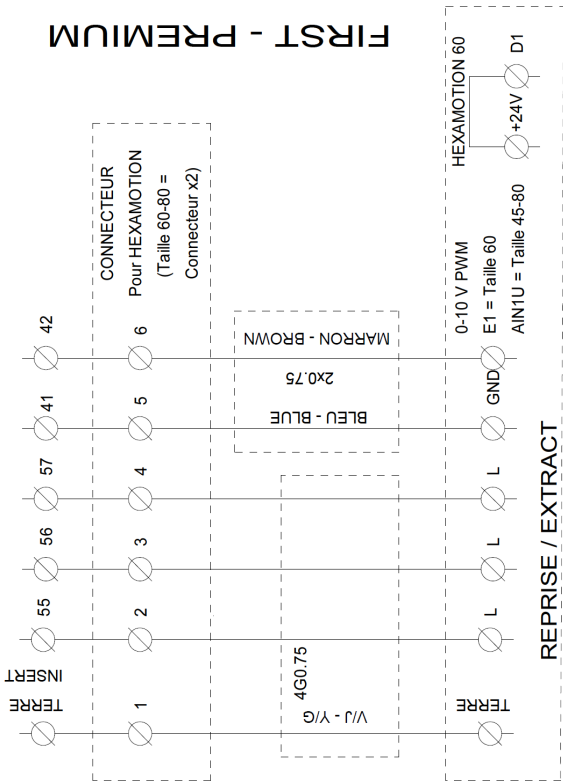

OPERATING AND COMMISSIONING INSTRUCTIONS

VIII.6. Curves

VIII.6.a. FREETIME[®]

FREETIME[®] 500

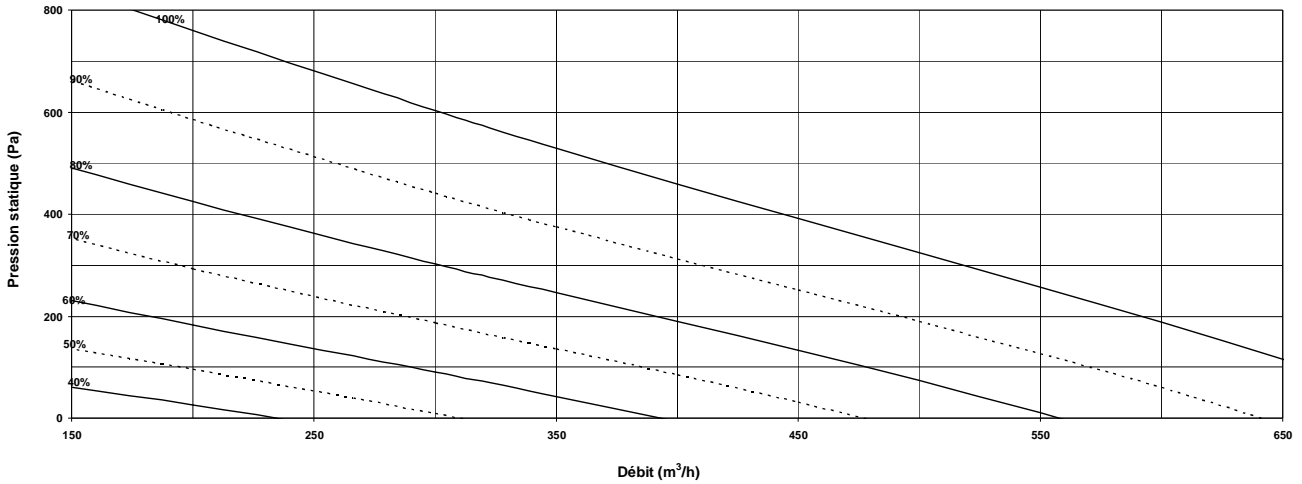

FREETIME[®] 800

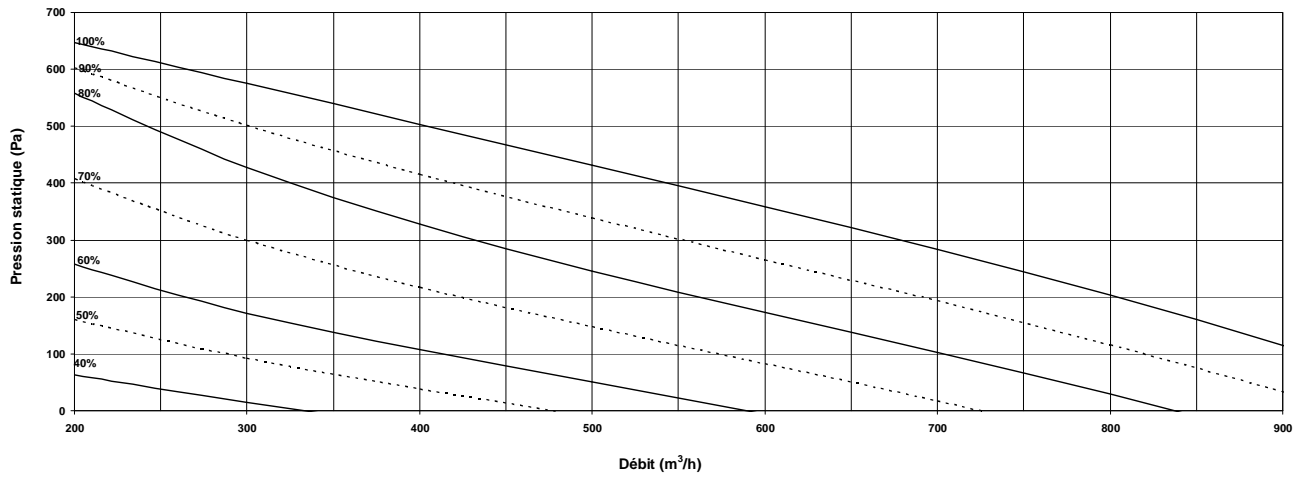

FREETIME[®] 1500

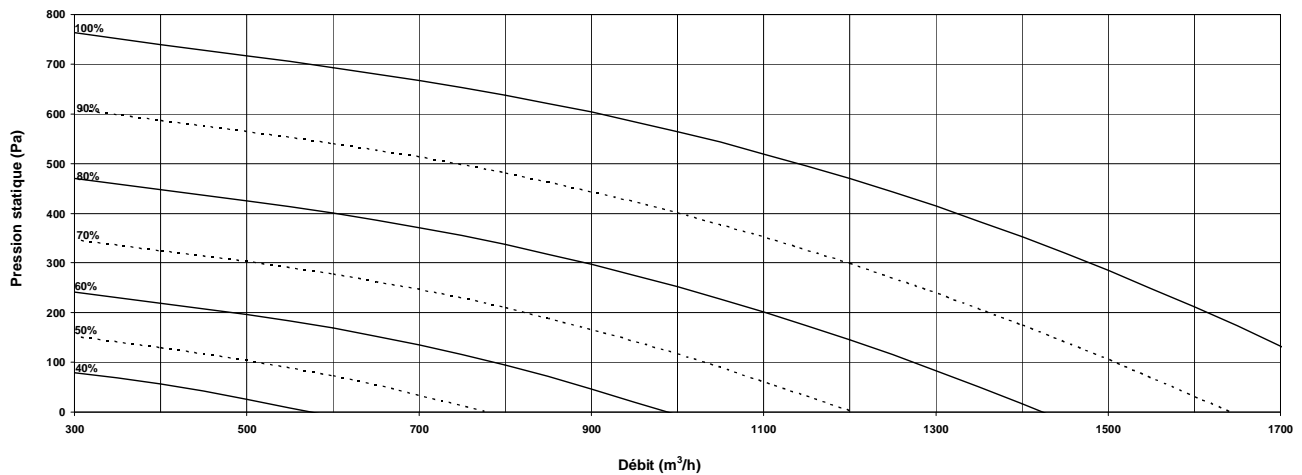

OPERATING AND COMMISSIONING INSTRUCTIONS

FREETIME® 2000

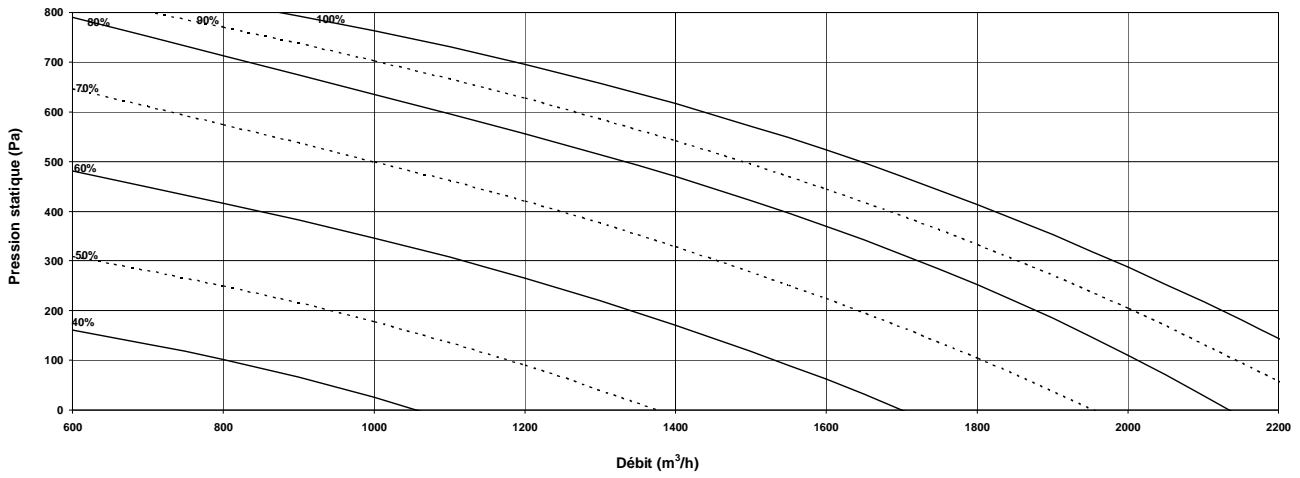

FREETIME® 2700

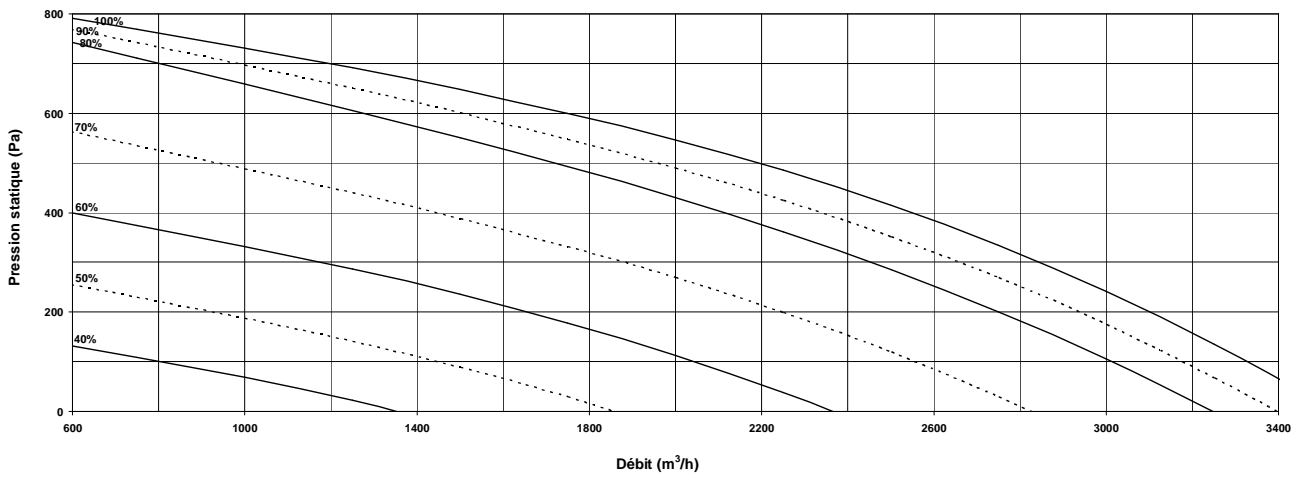

FREETIME® 3500

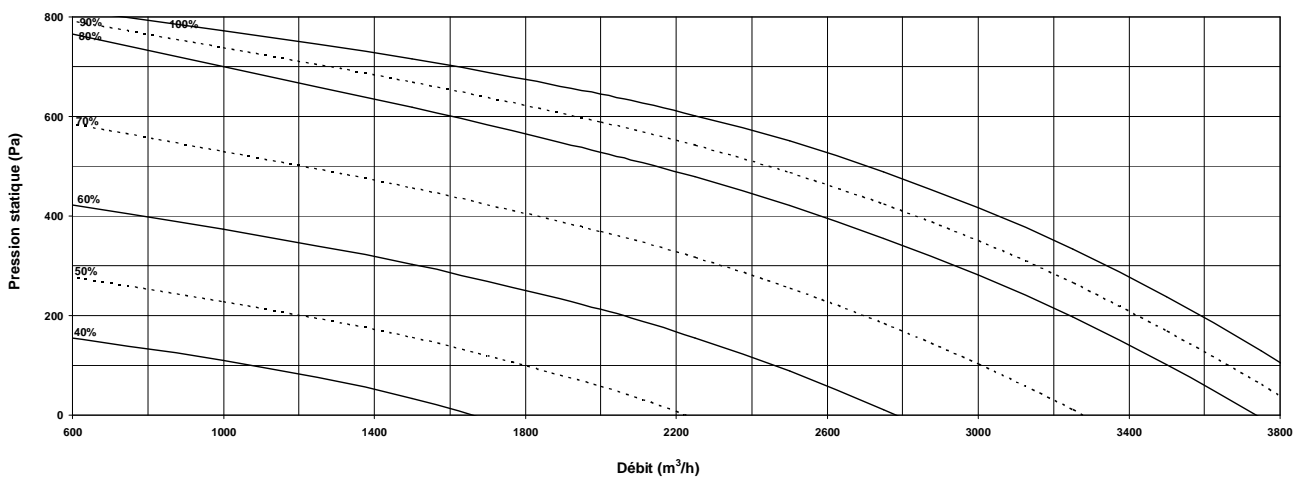

OPERATING AND COMMISSIONING INSTRUCTIONS

VIII.6.b. HEXAMOTION[®]

HEXAMOTION[®] 05

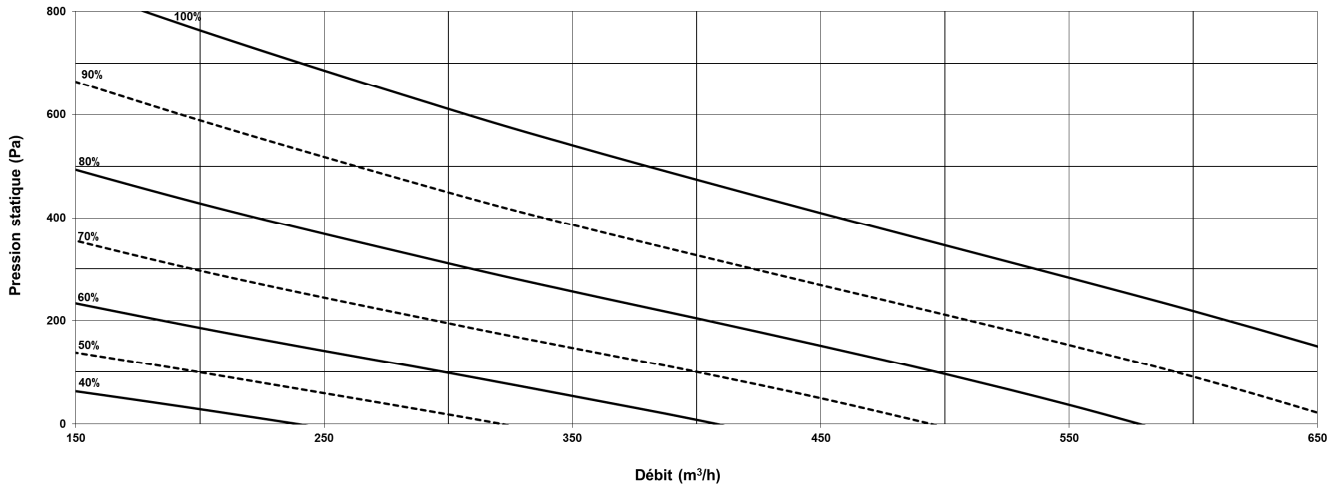

HEXAMOTION[®] 08

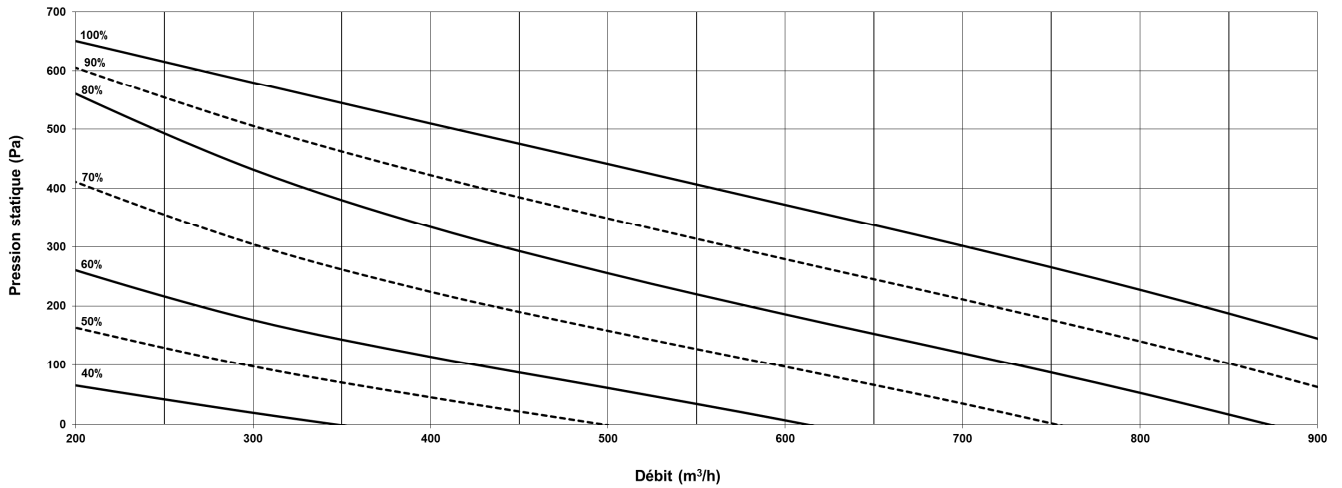

HEXAMOTION[®] 15

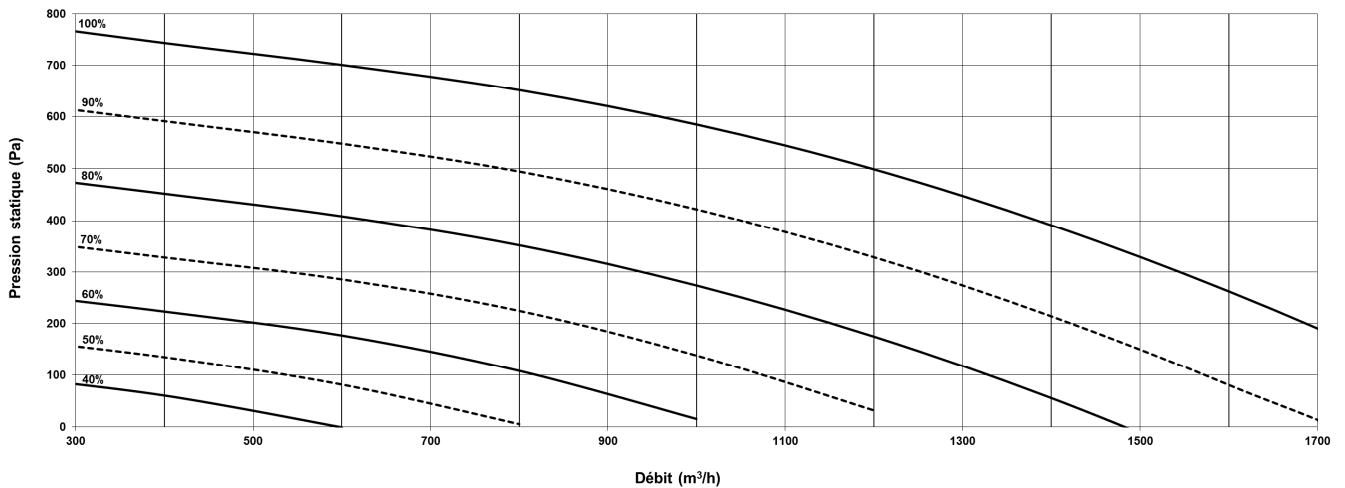

OPERATING AND COMMISSIONING INSTRUCTIONS

HEXAMOTION[®] 20

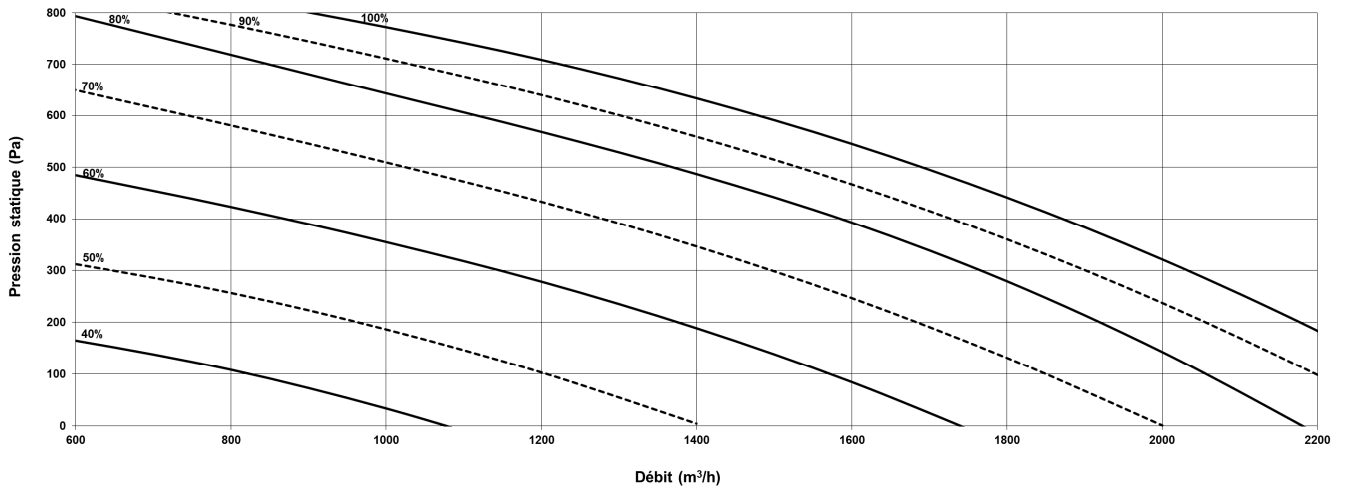

HEXAMOTION[®] 27

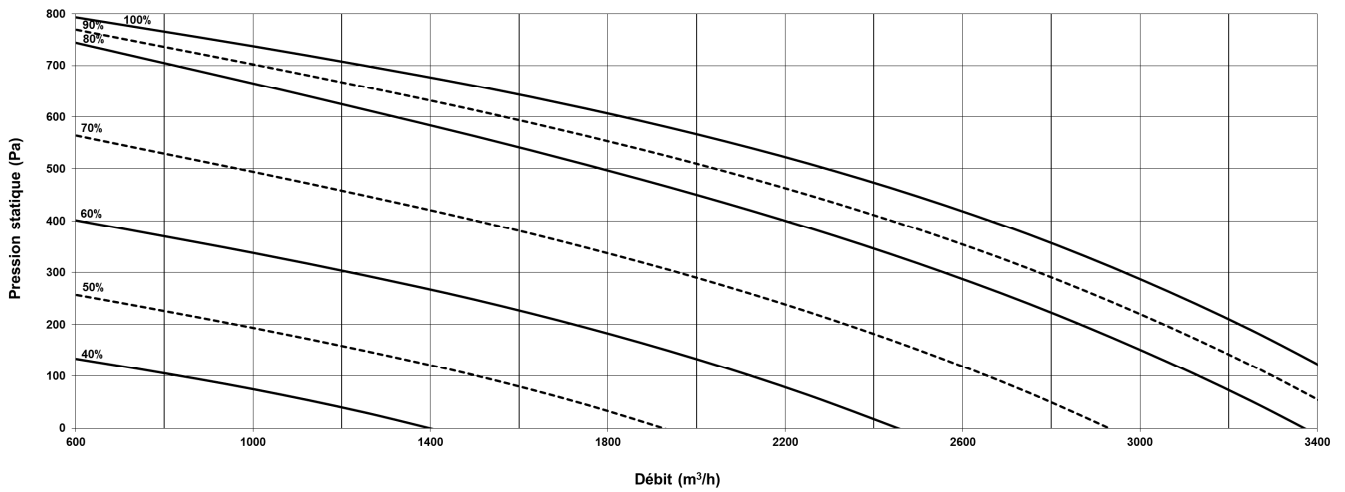

HEXAMOTION[®] 35

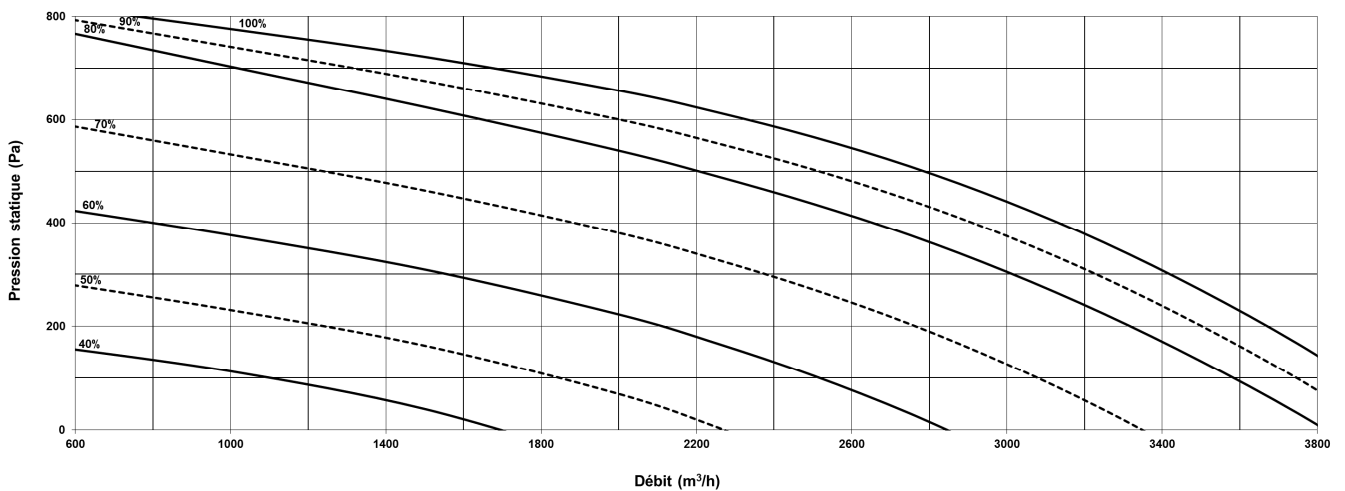

OPERATING AND COMMISSIONING INSTRUCTIONS

HEXAMOTION[®] 45

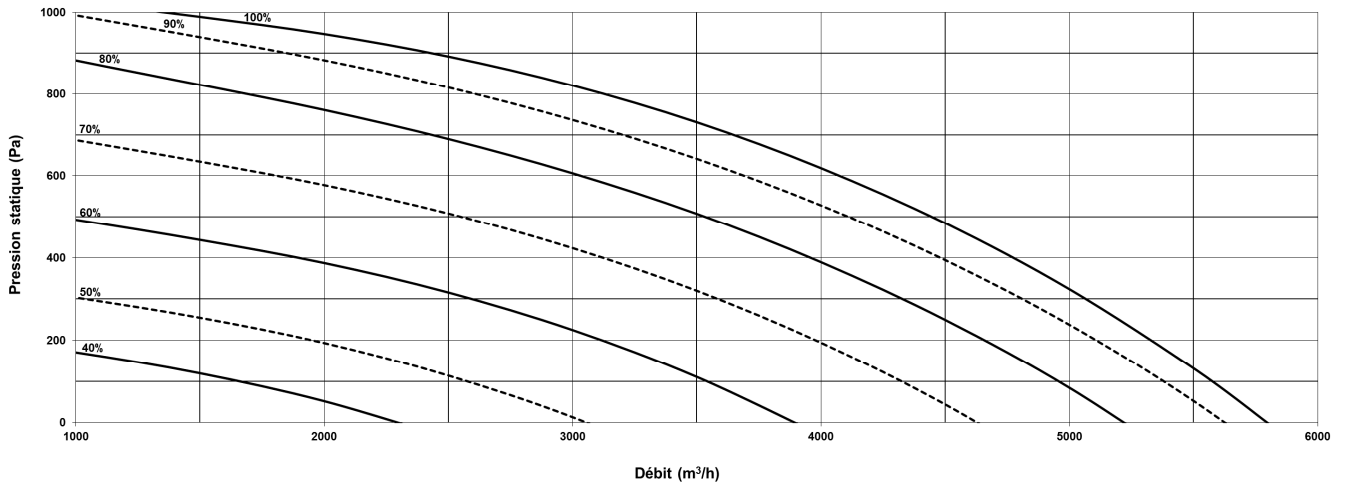

HEXAMOTION[®] 60

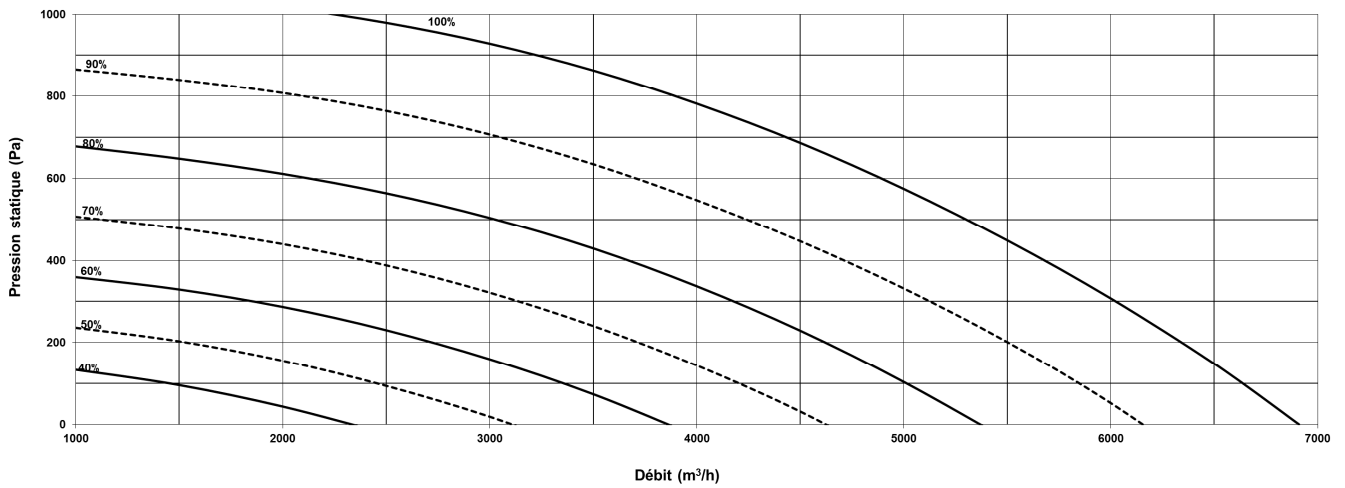

HEXAMOTION[®] 80

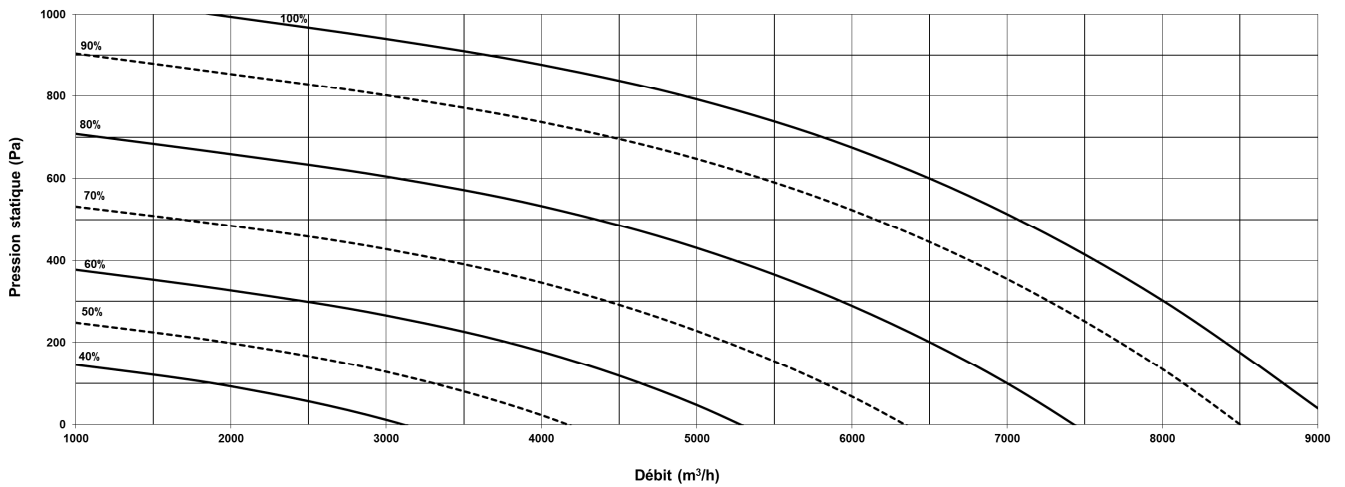

OPERATING AND COMMISSIONING INSTRUCTIONS

VIII.7. MODBUS and BACNET tables

INPUT REGISTER

Function	Description	Exo type	Modbus Adress	Bacnet Adress
Unit operation state	Modbus : 0= Stop 1= Start 2= Start low speed 3= Start max speed 4= Start normal speed 5= In operation 8= CO2 operation 9= Night cooling 11= Stopped BACNET : 1= Stop 2= Start 3= Low speed start 4= Max speed start 5= Normal speed start 6= In operation 9= CO2 operation 10= Night cooling operation 12= Stopped	X	3	MSV,40003
Outdoor temperature	In °C	R	1	AV,40001
Operating time of the supply fan	In hours	R	4	AV,40004
Operating time of the extract fan	In hours	R	5	AV,40005
Supply air temperature	In °C	R	7	AV,40007
Extract air temperature	In °C	R	9	AV,40009
Supply air pressure	In Pa for LOBBY [®] version	R	13	AV,40013
Extract air pressure	In Pa for LOBBY [®] version	R	14	AV,40014
Supply air flow	In m3/h for MAC2 [®] and QUATTRO [®] versions	R	15	AV,40015
Extract air flow	In m3/h for MAC2 [®] and QUATTRO [®] versions	R	16	AV,40016
CO2	In ppm for DIVA [®] and QUATTRO [®] versions	R	17	AV,40017
Humidity	In %	R	23	AV,40023
Analog output	0-10V Heating (water only)	R	54	AV,40119
Analog output	0-10V Heat exchanger	R	55	AV,40120
Analog output	0-10V Cooling	R	56	AV,40121
Analog output	0-10V SAF	R	57	AV,40122
Analog output	0-10V EAF	R	58	AV,40123

OPERATING AND COMMISSIONING INSTRUCTIONS

HOLDING REGISTER

Function	Description	Exo type	Modbus Adress	Bacnet Adress	Factory Value
Supply setpoint	Set in constant supply	R	1	AV,30001	18
Supply setpoint	Set in constant supply ext comp for out temp -20°C	R	10	AV,30010	25
Supply setpoint	Set in constant supply ext comp for out temp -15°C	R	11	AV,30011	24
Supply setpoint	Set in constant supply ext comp for out temp -10°C	R	12	AV,30012	23
Supply setpoint	Set in constant supply ext comp for out temp -5°C	R	13	AV,30013	23
Supply setpoint	Set in constant supply ext comp for out temp -0°C	R	14	AV,30014	22
Supply setpoint	Set in constant supply ext comp for out temp +5°C	R	15	AV,30015	20
Supply setpoint	Set in constant supply ext comp for out temp +10°C	R	16	AV,30016	18
Supply setpoint	Set in constant supply ext comp for out temp +15°C	R	17	AV,30017	18
Extract setpoint	Set in extract control	R	18	AV,30018	21
HS supply setpoint	In % for ECO and DIVA [®] versions	R	424	AV,30424	70
LS supply setpoint	In % for ECO and DIVA [®] versions	R	425	AV,30425	50
HS extract setpoint	In % for ECO and DIVA [®] versions	R	426	AV,30426	70
LS extract setpoint	In % for ECO and DIVA [®] versions	R	427	AV,30427	50
HS pressure supply setpoint	In Pa for LOBBY [®] version	R	24	AV,30024	150
LS pressure supply setpoint	In Pa for LOBBY [®] version	R	25	AV,30025	150
HS pressure extract setpoint	In Pa for LOBBY [®] version	R	26	AV,30026	150
LS pressure extract setpoint	In Pa for LOBBY [®] version	R	27	AV,30027	150
HS supply air flow setpoint	In m3/h for MAC2 [®] and QUATTRO [®] versions	R	28	AV,30028	xxx
LS supply air flow setpoint	In m3/h for MAC2 [®] and QUATTRO [®] versions	R	29	AV,30029	xxx
HS extract air flow setpoint	In m3/h for MAC2 [®] and QUATTRO [®] versions	R	30	AV,30030	xxx
LS extract air flow setpoint	In m3/h for MAC2 [®] and QUATTRO [®] versions	R	31	AV,30031	xxx
CO2 setpoint	In ppm for DIVA [®] and QUATTRO [®] versions	R	32	AV,30032	1000
Unit operation mode forcing	MODBUS 0= Manual stop 1= Manual low speed 2= Manual high speed 3= Auto	X	368	MSV,30368	3
	BACNET 1= Manual stop 2= Manual low speed 3= Manual high speed 4= Auto				4

OPERATING AND COMMISSIONING INSTRUCTIONS**INPUT STATUS REGISTER**

Function	Description	Exo type	Modbus Adress	Bacnet Adress
Active alarm	If 1 = ALARM	L	30	BV,20030
SAF fault	If 1 = ALARM	L	33	BV,20033
EAF fault	If 1 = ALARM	L	34	BV,20034
Filter fault	If 1 = ALARM	L	38	BV,20038
Antifreeze fault	If 1 = ALARM	L	40	BV,20040
Fire fault	If 1 = ALARM	L	42	BV,20042
Overheating fault (electrical heater)	If 1 = ALARM	L	55	BV,20055
Battery fault	If 1 = ALARM	L	80	BV,20080

OPERATING AND COMMISSIONING INSTRUCTIONS